



**DOGHER**  
 TOOLS  
*Making Solutions*

<p>25 mm 1/4"</p> 	166	<p>30 mm • 75 mm 5/16"</p> 	178
<p>50 mm 90 mm 1/4"</p> 	169	<p>30 mm • 75 mm 10 mm</p> 	181
<p>110 mm 125 150 mm 200 250 mm 1/4"</p> 	171	 	182
<p>25 mm 1/4" TiN</p> 	174	  	183
<p>30 mm 1/4" Bluefire</p> 	175	  	185
<p>50 mm 75 mm 100 150 mm 1/4"</p> 	176		

# Embouts de Vissage 400



# Embout de Vissage

Embout forgés avec une géométrie qui permet un accouplage parfait avec la vis.  
Le cou central plus souple offre une résistance élevée à la rupture par torsion.

1/4" • 25 mm



25 mm

1/4"

S2

• Respecter les quantités du conditionnement.



400

Phillips



400

Boîte de 3 Embouts Phillips



Logo	Part N°	€/Unité	Unités	Part N°	€/Unité	
	-	-	10	400-PH0-10	12,86	
	2	400-PH1-2	2,63	10	400-PH1-10	7,59
	2	400-PH2-2	2,63	10	400-PH2-10	7,59
	2	400-PH3-2	2,63	10	400-PH3-10	7,59
	-	-	10	400-PH4-10	12,86*	

Boîte de 3 Embouts PH1 • PH2 • PH3

Part N°	€
400-001	3,28

\* Jusqu'à fin des stocks

401

Pozidriv



401

Boîte de 3 Embouts Pozidriv



Logo	Part N°	€/Unité	Unités	Part N°	€/Unité	
	-	-	10	401-PZ0-10	12,86	
	2	401-PZ1-2	2,63	10	401-PZ1-10	7,59
	2	401-PZ2-2	2,63	10	401-PZ2-10	7,59
	2	401-PZ3-2	2,63	10	401-PZ3-10	7,59
	-	-	10	401-PZ4-10	12,86*	

Boîte de 3 Embouts PZ1 • PZ2 • PZ3

Part N°	€
401-001	3,28

\* Jusqu'à fin des stocks

1/4" • 25 mm

25 mm 1/4" S2

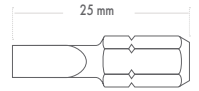

• Respecter les quantités du conditionnement.

## 400

### Présentoirs d'embouts de Vissage

10 Boîtes d'embouts PH2

Part N°	€
400-001J	75,90

10 Boîtes d'embouts PZ2

Part N°	€
400-002J	75,90

5 Boîtes d'embouts PH2 PZ2

Part N°	€
400-003J	75,90

3 Boîtes d'embouts PH2 PZ2

1 Boîte d'embouts PH2x50 PZ2x50

2 Porte- Embouts Magnétiques 443-050

Part N°	€
400-004J	107,30

10 Pcs



150 x 155 x 200 mm

## 402

### Plat



A mm	B mm		Part N°	€/
3	0,5	10	402-030-10	14,28
3,5	0,6	10	402-035-10	14,28
4	0,8	10	402-040-10	14,28
4,5	0,8	10	402-045-10	14,28
5	1	10	402-050-10	14,28
5,5	1	10	402-055-10	14,28
6	1,2	10	402-060-10	14,28
6,5	1,2	10	402-065-10	14,28
8	1,2	10	402-080-10	14,28

## 404

### Torx Sécurité



		Part N°	€/
TS10	10	404-TS10-10	26,93
TS15	10	404-TS15-10	26,93
TS20	10	404-TS20-10	26,93
TS25	10	404-TS25-10	26,93
TS27	10	404-TS27-10	26,93
TS30	10	404-TS30-10	26,93
TS40	10	404-TS40-10	26,93

# Embouts de Vissage

1/4" • 25 mm



25 mm

1/4"

S2

• Respecter les quantités du conditionnement.

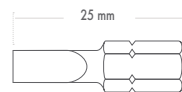

**403**

Torx



**405**

Hexagonal



		Part N°	€/		Part N°	€/
T05	-	-	-	-	403-T05-10	19,04
T06	-	-	-	-	403-T06-10	19,04
T07	-	-	-	-	403-T07-10	19,04
T08	-	-	-	-	403-T08-10	19,04
T09	-	-	-	-	403-T09-10	19,04
T10	2	403-T10-2	3,93	10	403-T10-10	14,08
T15	2	403-T15-2	3,93	10	403-T15-10	14,08
T20	2	403-T20-2	3,93	10	403-T20-10	14,08
T25	2	403-T25-2	3,93	10	403-T25-10	14,08
T27	-	-	-	-	403-T27-10	14,08
T30	2	403-T30-2	3,93	10	403-T30-10	14,08
T40	2	403-T40-2	3,93	10	403-T40-10	14,08

		Part N°	€/
HX1,5	10	405-HX015-10	14,45
HX2	10	405-HX020-10	14,45
HX2,5	10	405-HX025-10	14,45
HX3	10	405-HX030-10	14,45
HX4	10	405-HX040-10	14,45
HX5	10	405-HX050-10	14,45
HX6	10	405-HX060-10	14,45
HX8	10	405-HX080-10	17,14
HX10	10	405-HX100-10	21,73

**406**

Robertson



		Part N°	€/
R1	10	406-R1-10	20,29
R2	10	406-R2-10	20,29
R3	10	406-R3-10	20,29

1/4" • 50 mm

50 mm 1/4" S2

• Respecter les quantités du conditionnement.

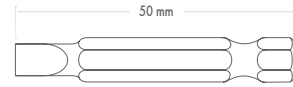

**410**

Phillips



50 mm



Icon	Part N°	€/	Part N°	€/
PH1	2 410-PH1-2	6,67	10 410-PH1-10	24,45
PH2	2 410-PH2-2	6,67	10 410-PH2-10	24,45
PH3	2 410-PH3-2	6,67	10 410-PH3-10	24,45
PH4*	-	-	-	24,45*

\* Jusqu'à fin des stocks

**411**

Pozidriv



50 mm



Icon	Part N°	€/	Part N°	€/
PZ1	2 411-PZ1-2	6,67	10 411-PZ1-10	24,45
PZ2	2 411-PZ2-2	6,67	10 411-PZ2-10	24,45
PZ3	2 411-PZ3-2	6,67	10 411-PZ3-10	24,45
PZ4*	-	-	-	24,45*

\* Jusqu'à fin des stocks

**412**

Plat



50 mm

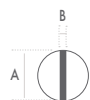

A mm	B mm	Part N°	€/
3	0,5	10 412-030-10	38,04
3,5	0,6	10 412-035-10	38,04
4	0,8	10 412-040-10	38,04
4,5	0,8	10 412-045-10	38,04
5	1	10 412-050-10	38,04
5,5	1	10 412-055-10	38,04
6	1,2	10 412-060-10	38,04
6,5	1,2	10 412-065-10	38,04
8	1,2	10 412-080-10	38,04

**413**

Torx



50 mm



Icon	Part N°	€/	Part N°	€/
T05	-	-	-	413-T05-10 46,60
T06	-	-	-	413-T06-10 46,60
T07	-	-	-	413-T07-10 46,60
T08	-	-	-	413-T08-10 46,60
T09	-	-	-	413-T09-10 46,60
T10	2 413-T10-2	11,38	10 413-T10-10	48,01
T15	2 413-T15-2	11,38	10 413-T15-10	48,01
T20	2 413-T20-2	11,38	10 413-T20-10	48,01
T25	2 413-T25-2	11,38	10 413-T25-10	48,01
T27	-	-	-	413-T27-10 48,01
T30	2 413-T30-2	11,38	10 413-T30-10	48,01
T40	2 413-T40-2	11,38	10 413-T40-10	48,01



# Embouts de Vissage

1/4" • 50 mm

1/4" • 90 mm



50 mm 1/4" S2

• Respecter les quantités du conditionnement.



414

Hexagonal



50 mm



		Part N°	€/
HX2	10	414-HX020-10	47,50
HX2,5	10	414-HX025-10	47,50
HX3	10	414-HX030-10	47,50
HX4	10	414-HX040-10	47,50
HX5	10	414-HX050-10	47,50
HX6	10	414-HX060-10	47,50
HX8	10	414-HX080-10	47,50

415

Robertson



50 mm



		Part N°	€/
R1	10	415-R1-10	31,50
R2	10	415-R2-10	31,50
R3	10	415-R3-10	31,50

416

Phillips



90 mm



		Part N°	€/
PH1	5	416-PH1-5	33,77
PH2	5	416-PH2-5	33,77
PH3	5	416-PH3-5	33,77

417

Pozidriv



90 mm



		Part N°	€/
PZ1	5	417-PZ1-5	33,77
PZ2	5	417-PZ2-5	33,77
PZ3	5	417-PZ3-5	33,77

418

Torx



90 mm



		Part N°	€/
T10	5	418-T10-5	41,85
T15	5	418-T15-5	41,85
T20	5	418-T20-5	41,85
T25	5	418-T25-5	41,85
T30	5	418-T30-5	41,85
T40	5	418-T40-5	41,85

1/4" • 110 mm



110 mm 1/4" S2

## 4110 Phillips



110 mm



		Part N°	€/
PH1	1	4110-PH1-1	7,50
PH2	1	4110-PH2-1	7,50
PH3	1	4110-PH3-1	7,50

## 4110 Pozidriv



110 mm



		Part N°	€/
PZ1	1	4110-PZ1-1	7,50
PZ2	1	4110-PZ2-1	7,50
PZ3	1	4110-PZ3-1	7,50

## 4110 Torx



110 mm



		Part N°	€/
T10	1	4110-T10-1	8,61
T15	1	4110-T15-1	8,61
T20	1	4110-T20-1	8,61
T25	1	4110-T25-1	8,61
T30	1	4110-T30-1	8,61
T40	1	4110-T40-1	8,61

# Embouts de Vissage

1/4" • 125 mm

1/4" • 150 mm



125 mm

1/4"

S2

4125

Phillips

4125

Pozidriv



125 mm



125 mm



		Part N°	€/
PH1	1	4125-PH1-1	7,97
PH2	1	4125-PH2-1	7,97
PH3	1	4125-PH3-1	7,97

		Part N°	€/
PZ1	1	4125-PZ1-1	7,97
PZ2	1	4125-PZ2-1	7,97
PZ3	1	4125-PZ3-1	7,97



150 mm

1/4"

S2

4150

Phillips

4150

Pozidriv



150 mm



150 mm



		Part N°	€/
PH1	1	4150-PH1-1	9,26
PH2	1	4150-PH2-1	9,26
PH3	1	4150-PH3-1	9,26

		Part N°	€/
PZ1	1	4150-PZ1-1	9,26
PZ2	1	4150-PZ2-1	9,26
PZ3	1	4150-PZ3-1	9,26

4150

Torx



150 mm

		Part N°	€/
T10	1	4150-T10-1	11,06
T15	1	4150-T15-1	11,06
T20	1	4150-T20-1	11,06
T25	1	4150-T25-1	11,06
T30	1	4150-T30-1	11,06
T40	1	4150-T40-1	11,06





1/4" • 200 mm

1/4" • 250 mm



200 mm

1/4"

S2

**4200**

Phillips

**4200**

Pozidriv



200 mm



200 mm



		Part N°	€/
PH2	1	4200-PH2-1	12,14

		Part N°	€/
PZ2	1	4200-PZ2-1	12,14

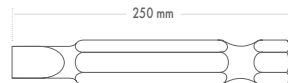

250 mm

1/4"

S2

**4250**

Phillips

**4250**

Pozidriv



250 mm



250 mm



		Part N°	€/
PH2	1	4250-PH2-1	15,22

		Part N°	€/
PZ2	1	4250-PZ2-1	15,22

# Embouts de Vissage

Embouts forgés avec revêtement TiN (nitrure de titane), ce qui confère à l'embout une durabilité jusqu'à 5 fois supérieure, en particulier dans les travaux en série.

TiN

1/4" • 25 mm

25 mm

1/4"

S2

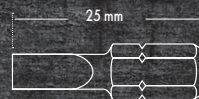

• Respecter les quantités du conditionnement.

TiN

420

Phillips



25 mm



TiN

421

Pozidriv



25 mm



Symbol	Qty	Part N°	€/Unit	Qty	Part N°	€/Unit
PH1	2	420-PH1-2	6,77	5	420-PH1-5	12,49
PH2	2	420-PH2-2	6,77	5	420-PH2-5	12,49
PH3	2	420-PH3-2	6,77	5	420-PH3-5	12,49

Symbol	Qty	Part N°	€/Unit	Qty	Part N°	€/Unit
PZ1	2	421-PZ1-2	6,77	5	421-PZ1-5	12,49
PZ2	2	421-PZ2-2	6,77	5	421-PZ2-5	12,49
PZ3	2	421-PZ3-2	6,77	5	421-PZ3-5	12,49

TiN

422

Plat



25 mm



TiN

423

Torx



25 mm



A mm	B mm	Qty	Part N°	€/Unit
4,5	0,8	5	422-045-5	15,57
5,5	1	5	422-055-5	15,57
6,5	1,2	5	422-065-5	15,57

Symbol	Qty	Part N°	€/Unit	Qty	Part N°	€/Unit
T10	2	423-T10-2	8,01	5	423-T10-5	15,57
T15	2	423-T15-2	8,01	5	423-T15-5	15,57
T20	2	423-T20-2	8,01	5	423-T20-5	15,57
T25	2	423-T25-2	8,01	5	423-T25-5	15,57
T27	-	-	-	5	423-T27-5	15,57
T30	2	423-T30-2	8,01	5	423-T30-5	15,57
T40	2	423-T40-2	8,01	5	423-T40-5	15,57



Embout forgé spécialement conçu pour travailler avec des visseuses à batterie.  
Le cou central, de moindre dureté, absorbe les chocs provoqués lors du vissage en évitant la rupture de la tête.  
La géométrie de l'embout permet un accouplage parfait avec les vis évitant les jeux pouvant provoquer des ruptures.

## Embout Impact

**Bluefire**



- Acier haute technologie S2
- Résistance à la torsion maximale
- Haute tenacité
- Géométrie spécifique offrant une durabilité maximale

30 mm

1/4"

S2



1/4" • 30 mm

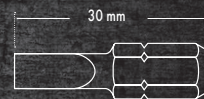

• Respecter les quantités de conditionnement.

427

Phillips



30 mm



		Part N°	€/		Part N°	€/
PH2	2	427-PH2-2	10,96	5	427-PH2-5	22,96
PH3	2	427-PH3-2	10,96	5	427-PH3-5	22,96

427

Pozidriv



30 mm



		Part N°	€/		Part N°	€/
PZ2	2	427-PZ2-2	10,96	5	427-PZ2-5	22,96
PZ3	2	427-PZ3-2	10,96	5	427-PZ3-5	22,96

427

Torx



30 mm



		Part N°	€/		Part N°	€/
T10	2	427-T10-2	11,15	5	427-T10-5	23,44
T15	2	427-T15-2	11,15	5	427-T15-5	23,44
T20	2	427-T20-2	11,15	5	427-T20-5	23,44
T25	2	427-T25-2	11,15	5	427-T25-5	23,44
T30	2	427-T30-2	11,15	5	427-T30-5	23,44
T40	2	427-T40-2	11,15	5	427-T40-5	23,44

443

Porte-Embout Impact Magnétique avec Anneau

60 mm

1/4"

1/4"



L mm		Part N°	€/
60	1	443-002	17,09

# Embouts Impact

1/4" • 50 mm

1/4" • 75 mm



**10X**  
Life



50 mm

1/4"

S2



• Respecter les quantités du conditionnement.

**425**

Phillips



50 mm



		Part N°	€/		Part N°	€/
PH2	2	425-PH2-2	11,65	5	425-PH2-5	24,68
PH3	2	425-PH3-2	11,65	5	425-PH3-5	24,68

**425**

Pozidriv

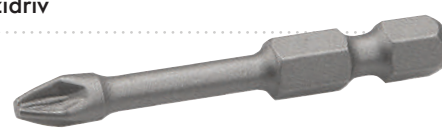

50 mm



		Part N°	€/		Part N°	€/
PZ2	2	425-PZ2-2	11,65	5	425-PZ2-5	24,68
PZ3	2	425-PZ3-2	11,65	5	425-PZ3-5	24,68

**426**

Phillips



75 mm

		Part N°	€/
PH2	5	426-PH2-5	34,06
PH3	5	426-PH3-5	34,06

**426**

Pozidriv



75 mm

		Part N°	€/
PZ2	5	426-PZ2-5	34,06
PZ3	5	426-PZ3-5	34,06



1/4" • 100 mm

1/4" • 150 mm

**Impact series**

**10X**  
Life



100 mm

1/4"

S2

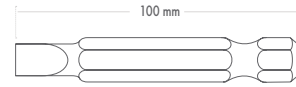

• Respecter les quantités du conditionnement.

**428**

Phillips

**428**

Pozidriv



100 mm



100 mm



		Part N°	€/
PH2	5	428-PH2-5	38,38
PH3	5	428-PH3-5	38,38

		Part N°	€/
PZ2	5	428-PZ2-5	38,38
PZ3	5	428-PZ3-5	38,38

150 mm

1/4"

S2

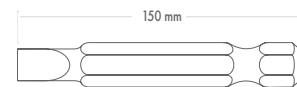

**429**

Phillips

**429**

Pozidriv



150 mm



150 mm



		Part N°	€/
PH2	5	429-PH2-5	46,92
PH3	5	429-PH3-5	46,92

		Part N°	€/
PZ2	5	429-PZ2-5	46,92
PZ3	5	429-PZ3-5	46,92

# Embouts de Vissage

5/16" • 30 mm



30 mm 5/16" S2

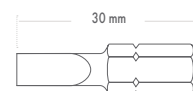

• Respecter les quantités du conditionnement.

## 430 Phillips



30 mm



		Part N°	€/
<b>PH1</b>	10	<b>430-PH1-10</b>	<b>24,74</b>
<b>PH2</b>	10	<b>430-PH2-10</b>	<b>24,74</b>
<b>PH3</b>	10	<b>430-PH3-10</b>	<b>24,74</b>
<b>PH4</b>	10	<b>430-PH4-10</b>	<b>24,74</b>

## 431 Pozidriv



30 mm



		Part N°	€/
<b>PZ1</b>	10	<b>431-PZ1-10</b>	<b>24,74</b>
<b>PZ2</b>	10	<b>431-PZ2-10</b>	<b>24,74</b>
<b>PZ3</b>	10	<b>431-PZ3-10</b>	<b>24,74</b>
<b>PZ4</b>	10	<b>431-PZ4-10</b>	<b>24,74</b>

## 432 Plat Large



30 mm

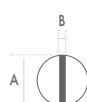

A mm	B mm		Part N°	€/
<b>8</b>	1,2	10	<b>432-080-10</b>	<b>26,08</b>
<b>10</b>	1,6	10	<b>432-100-10</b>	<b>33,63</b>
<b>12</b>	1,8	10	<b>432-120-10</b>	<b>47,04</b>
<b>14</b>	2,3	10	<b>432-140-10</b>	<b>72,94</b>

## 433 Torx



30 mm



		Part N°	€/
<b>T25</b>	1	<b>433-T25</b>	<b>4,20</b>
<b>T30</b>	1	<b>433-T30</b>	<b>4,20</b>
<b>T40</b>	10	<b>433-T40-10</b>	<b>27,91</b>
<b>T45</b>	10	<b>433-T45-10</b>	<b>27,91</b>
<b>T50</b>	10	<b>433-T50-10</b>	<b>27,91</b>
<b>T55</b>	10	<b>433-T55-10</b>	<b>40,83</b>
<b>T60</b>	10	<b>433-T60-10</b>	<b>74,09</b>

5/16" • 30 mm

5/16" • 75 mm



30 mm    75 mm    5/16"    S2

• Respecter les quantités du conditionnement.

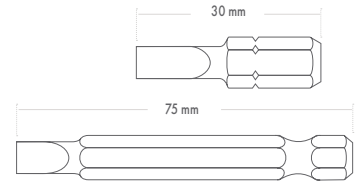

## 434

Torx Sécurité



30 mm



		Part N°	€/
TS45	10	434-TS45-10	49,97
TS50	10	434-TS50-10	49,97
TS55	10	434-TS55-10	54,47

## 435

Hexagonal



30 mm



		Part N°	€/
HX4	1	435-HX4	5,14
HX5	1	435-HX5	5,14
HX6	1	435-HX6	5,14
HX8	1	435-HX8	5,14
HX10	10	435-HX10-10	31,93
HX12	10	435-HX12-10	44,73
HX14	10	435-HX14-10	47,68

## 436

XZN



30 mm



		Part N°	€/
XZN8	5	436-XZN8	32,73
XZN10	5	436-XZN10	32,73

## 436

XZN



75 mm



		Part N°	€/
XZN8	5	436-XZN8-75	37,96
XZN10	5	436-XZN10-75	37,96

# Embouts de Vissage

10 mm • 30 mm



30 mm 10 mm S2

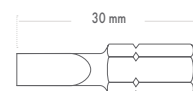

437

Hexagonal



		Part N°	€/
HX4	5	437-HX4	14,01
HX5	5	437-HX5	14,01
HX6	5	437-HX6	14,01
HX7	5	437-HX7	14,01
HX8	5	437-HX8	14,01
HX10	5	437-HX10	14,01
HX12	5	437-HX12	14,99

437

Ribe



		Part N°	€/
RIBE6	5	437-RIBE6	16,39
RIBE7	5	437-RIBE7	16,39
RIBE8	5	437-RIBE8	16,39
RIBE9	5	437-RIBE9	16,39
RIBE10	5	437-RIBE10	16,39
RIBE12	5	437-RIBE12	21,88
RIBE14	5	437-RIBE14	24,98

437

XZN



		Part N°	€/
XZN5	5	437-XZN5	14,76
XZN6	5	437-XZN6	14,76
XZN8	5	437-XZN8	14,76
XZN10	5	437-XZN10	14,76
XZN12	5	437-XZN12	19,68
XZN14	5	437-XZN14	22,48

437

Torx



		Part N°	€/
T20	5	437-T20	14,76
T25	5	437-T25	14,76
T30	5	437-T30	14,76
T40	5	437-T40	14,76
T45	5	437-T45	14,76
T50	5	437-T50	14,76
T55	5	437-T55	14,76

437

Robertson



		Part N°	€/
R8	5	437-R8	15,60
R10	5	437-R10	16,76



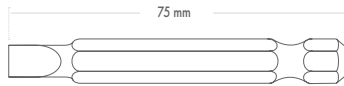

**437**

Hexagonal



75 mm



		Part N°	€/
<b>HX4</b>	5	<b>437-HX4-75</b>	<b>21,51</b>
<b>HX5</b>	5	<b>437-HX5-75</b>	<b>21,51</b>
<b>HX6</b>	5	<b>437-HX6-75</b>	<b>21,51</b>
<b>HX7</b>	5	<b>437-HX7-75</b>	<b>21,51</b>
<b>HX8</b>	5	<b>437-HX8-75</b>	<b>21,51</b>
<b>HX10</b>	5	<b>437-HX10-75</b>	<b>21,51</b>
<b>HX12</b>	5	<b>437-HX12-75</b>	<b>22,48</b>

10 mm • 115 mm

<b>HX10</b>	1	<b>437-HX10-115</b>	<b>23,69</b>
-------------	---	---------------------	--------------

**437**

Ribe



75 mm



		Part N°	€/
<b>RIBE6</b>	5	<b>437-RIBE6-75</b>	<b>23,77</b>
<b>RIBE7</b>	5	<b>437-RIBE7-75</b>	<b>23,77</b>
<b>RIBE8</b>	5	<b>437-RIBE8-75</b>	<b>23,77</b>
<b>RIBE9</b>	5	<b>437-RIBE9-75</b>	<b>26,45</b>
<b>RIBE10</b>	5	<b>437-RIBE10-75</b>	<b>26,45</b>
<b>RIBE12</b>	5	<b>437-RIBE12-75</b>	<b>32,23</b>
<b>RIBE14</b>	5	<b>437-RIBE14-75</b>	<b>43,03</b>

**437**

XZN



75 mm



		Part N°	€/
<b>XZN5</b>	5	<b>437-XZN5-75</b>	<b>17,55</b>
<b>XZN6</b>	5	<b>437-XZN6-75</b>	<b>17,55</b>
<b>XZN8</b>	5	<b>437-XZN8-75</b>	<b>17,55</b>
<b>XZN10</b>	5	<b>437-XZN10-75</b>	<b>22,43</b>
<b>XZN12</b>	5	<b>437-XZN12-75</b>	<b>27,73</b>

**437**

Torx



75 mm



		Part N°	€/
<b>T20</b>	5	<b>437-T20-75</b>	<b>20,13</b>
<b>T25</b>	5	<b>437-T25-75</b>	<b>20,13</b>
<b>T30</b>	5	<b>437-T30-75</b>	<b>20,13</b>
<b>T40</b>	5	<b>437-T40-75</b>	<b>20,18</b>
<b>T45</b>	5	<b>437-T45-75</b>	<b>20,18</b>
<b>T50</b>	5	<b>437-T50-75</b>	<b>20,18</b>
<b>T55</b>	5	<b>437-T55-75</b>	<b>28,25</b>

10 mm • 115 mm

<b>T55</b>	1	<b>437-T55-115</b>	<b>30,50</b>
------------	---	--------------------	--------------

# Embouts de Vissage



10 mm

Jeux d'Embouts de Vissage

438

Jeux d'Embouts de Vissage Hexagonaux avec Porte-Embouts

15

Pcs

10 mm

S2



Porte-embouts

10 mm ▶ ◀ 1/2" (543-027)

10 mm x 30 mm HX4 • HX5 • HX6 • HX7 • HX8 • HX10 • HX12

10 mm x 75 mm HX4 • HX5 • HX6 • HX7 • HX8 • HX10 • HX12

Part N°	€
438-004	54,24

438

Jeux d'Embouts de Vissage Ribe avec Porte-Embouts

15

Pcs

10 mm

S2



Porte-embouts

10 mm ▶ ◀ 1/2" (543-027)

10 mm x 30 mm RIBE6 • RIBE7 • RIBE8 • RIBE9  
RIBE10 • RIBE12 • RIBE14

10 mm x 75 mm RIBE6 • RIBE7 • RIBE8 • RIBE9  
RIBE10 • RIBE12 • RIBE14

Part N°	€
438-005	74,03

438

Jeux d'Embouts de Vissage XZN avec Porte-Embouts

11

Pcs

10 mm

S2



Porte-embouts

10 mm ▶ ◀ 1/2" (543-027)

10 mm x 30 mm XZN5 • XZN6 • XZN8 • XZN10 • XZN12

10 mm x 75 mm XZN5 • XZN6 • XZN8 • XZN10 • XZN12

Part N°	€
438-006	48,92

438

Jeux d'Embouts de Vissage Torx avec Porte-Embouts

15

Pcs

10 mm

S2



Porte-embouts

10 mm ▶ ◀ 1/2" (543-027)

10 mm x 30 mm T20 • T25 • T30 • T40 • T45 • T50 • T55

10 mm x 75 mm T20 • T25 • T30 • T40 • T45 • T50 • T55

Part N°	€
438-007	52,97

**440**

Douille Hexagonale Magnétique



Ø	Q	Part N°	€/Q
5	2	440-050	11,97
5,5	2	440-055	11,97
6	2	440-060	11,97
1/4	2	440-1/4	11,97
7	2	440-070	11,97
5/16	2	440-5/16	12,76
8	2	440-080	12,21
3/8	2	440-3/8	12,76
10	2	440-100	12,84
11	2	440-110	13,09
12	2	440-120	13,41
13	2	440-130	13,96

**441**

Douille Hexagonale Magnétique Longue



Ø	Q	Part N°	€/Q
6	2	441-060	13,17
7	2	441-070	13,17
8	2	441-080	13,44
10	2	441-100	14,12
11	2	441-110	14,39
12	2	441-120	14,76
13	2	441-130	15,36

**440**

Kit de Douilles Hexagonales Magnétiques

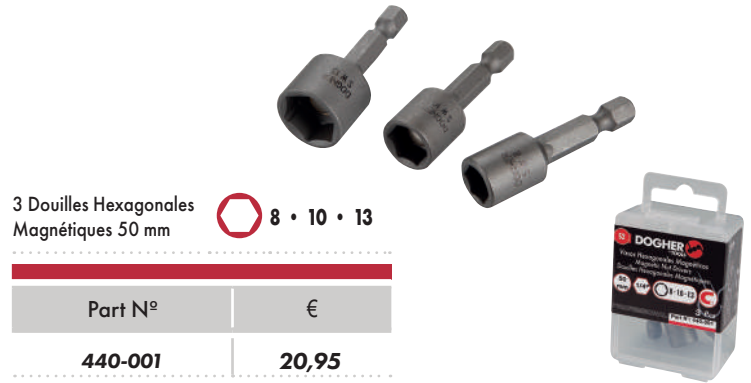

3 Douilles Hexagonales Magnétiques 50 mm 8 • 10 • 13

Part N°	€
440-001	20,95

7 Douilles Hexagonales Magnétiques 50 mm 6 • 7 • 8 • 10  
13 • 5/16 • 3/8

Part N°	€
440-005	50,90

3 Douilles Hex. Mag. 50 mm 8 • 5/16 • 3/8  
4 Douilles Hex. Mag. 65 mm 6 • 7 • 10 • 13

Part N°	€
440-006	52,10



3 Douilles Hexagonales Magnétiques 65 mm 8 • 10 • 13

Part N°	€
441-001	22,90

7 Douilles Hexagonales Magnétiques 65 mm 6 • 7 • 8 • 10  
11 • 12 • 13

Part N°	€
441-005	55,87

# Embouts de Vissage

Douilles Hexagonales et Porte-Embouts



443

Porte-Embouts Magnétique avec Anneau

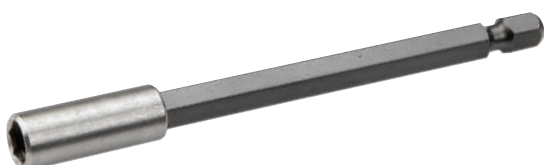

L mm		Part N°	€
50	1	443-050	6,43
58	1	443-058	6,73
74	1	443-074	11,43
100	1	443-100	13,67
200	1	443-200	16,72

445

Porte-Embouts Magnétique SDS Plus avec Anneau



L mm		Part N°	€
78	1	445-001	15,76

440

Kit de Douilles Magnétiques et Porte-Embouts



5 Douilles Hex. Mag. 50 mm  
2 Porte-Embouts 50-74 mm

6 • 7 • 8  
10 • 13

Part N°	€
440-007	56,00



5 Douilles Hex. Mag.  
2 Porte-Embouts 50-58 mm

8 • 10 • 13  
8 • 10 50 mm  
65 mm

Part N°	€
440-008	53,11



**444**

Rallonge Flexible

1/4"  
1/4"  
300 mm



Part N°	€
444-001	28,92

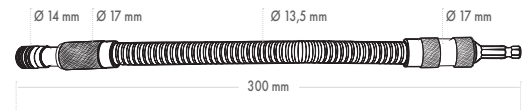

**443**

Renvoi d'angle pour Embouts de Vissage 1/4"

1/4"  
1/4"



- Pour embouts de vissage et forets à queue hexagonale
- Conçu pour travailler dans les espaces réduits.
- Il est recommandé de l'utiliser exclusivement avec des visseuses sans fil.

Part N°	€
443-001	32,31

## Jeux d'Embouts de Vissage

**438**

Jeux d'Embouts de Vissage avec Porte-Embouts

**32**  
Pcs

1/4"  
25 mm



★ T06 • T07 • T08 • T09 • T10 • T15 • T20 • T25 • T27 • T30 • T40    ● HX3 • HX4 • HX5 • HX6

— 3 • 4 • 5 • 6 • 7    ★ PZ0 • PZ1 • PZ2 • PZ3    ★ PH0 • PH1 • PH2 (x3) • PH3

Adaptateur

1/4" ◀ ▶ 1/4" (509-030)

Porte-Embouts Magnétique avec Anneau • 60 mm

1/4" ◯ ▶ 1/4"

Part N°	€
438-001	41,94

**338**

Jeux d'Embouts de Vissage avec Clé à Cliquet

**32**  
Pcs

1/4"  
25 mm



★ T06 • T07 • T08 • T09 • T10 • T15 • T20 • T25 • T30 • T40    ● HX3 • HX4 • HX5 • HX6

— 3 • 4 • 5 • 6 • 7    ★ PZ0 • PZ1 • PZ2 • PZ3    ★ PH0 • PH1 • PH2 • PH3

■ R0 • R1 • R2 • R3

Clé à Cliquet



Part N°	€
438-002	44,60

# Embout de Vissage

Jeux d'Embout de Vissage



438

Jeux d'Embout de Vissage avec Clé à Cliquet

11

Pcs

1/4"

25

mm



PH1 • PH2 • PH3

PZ1 • PZ2 • PZ3

3 • 4 • 5 • 6

Clé à Cliquet



Part N°

€

438-003

39,69



10

Pcs

230 x 210 x 155 mm

Part N°

€

438-003J

396,90

438

Coffret Tournevis à Cliquet 1/4" et Embouts de Vissage

58

Pcs

1/4"

25

mm



3 • 4 • 4,5 • 5 • 6 • 7 • 8

PZ0 • PZ1 • PZ2 • PZ3

1 • 2 • 3

PH0 • PH1 • PH2 • PH3

TW1 • TW2 • TW3 • TW4

HX1,5

HXS2,0 • HXS2,5 • HXS3,0 • HXS4,0 • HXS5,0 • HXS6,0

R0 • R1 • R2 • R3

TQ06 • TQ08 • TQ10

T5 • T6

TS7 • TS8 • TS9 • TS10 • TS15 • TS20 • TS25 • TS30 • TS40

XZN4 • XZN5 • XZN6 • XZN8

4 • 6 • 8 • 10

Porte-embouts Magnétique - 60 mm / Tournevis Réf. 343-007

Adaptateur 1/4" ◀ ▶ 1/4" (509-030)

Part N°

€

438-008

65,65

7

Pcs



275 x 290 x 140 mm

Part N°

€

438-008J

459,55