



DOGHER
© TOOLS



	589		592
	589		593
	590		595
	591		596

Inox 20000





Les outils en acier inoxydable DOGHER TOOLS sont fabriqués en acier inoxydable AISI 420, un acier martensitique, durcissable et ferromagnétique résistant à la corrosion, son procédé de trempe lui confère la dureté nécessaire pour affronter le travail quotidien.

Sa teneur élevée en chrome lui confère une excellente résistance à la corrosion. Au contact de l'environnement, il génère naturellement une couche protectrice d'oxyde de chrome qui protège la surface et se régénère chaque fois que l'outil est endommagé.

Un autre des grands avantages de l'acier inoxydable, si on le compare à d'autres métaux, est son degré de résistance aux températures extrêmes sans subir de détérioration ou altérations. C'est d'ailleurs le métal qui résiste le mieux au feu et sans dégagement de vapeurs toxiques. D'autre part, il peut également être soumis à des températures hivernales sans risque de fragilisation ou de casse.

Les outils en acier inoxydable DOGHER TOOLS possèdent une excellente ductilité, élasticité et dureté qui les rendent spécialement indiqués pour tout type de projet. Ils possèdent également une excellente résistance à l'usure.

Toutes ces caractéristiques nous permettent d'utiliser les outils Inox Dogher Tools dans les applications suivantes:

1. Laboratoires, Biotechnologie, Biomédecine, Salles Blanches, entreprises Pharmaceutiques....
2. Installations de traitement des aliments et installations en milieux Humides
3. Construction navale, construction, automobile, Aéronautique, Applications maritimes, Stations Essence et d'Énergie...
4. Industrie chimique
5. Installations de désalement
6. Offshore (pétrole-gaz)
7. Centrales nucléaires



20025

Servante Métallique 5 Tiroirs

Inox

Aisi 304



• Dim. Tiroir
568 x 398 mm

460 mm 846 mm 680 mm

Part N°	€
20025-007	2.071,34

20025

Servante Métallique 7 Tiroirs

Inox

Aisi 304



• Dim. Tiroir
644 x 399 mm

500 mm 998 mm 760 mm

Part N°	€
20025-005	2.397,85

20266

Pince Multiprise à Secteurs

Inox

Aisi 420



L mm	L"	Ø mm	Part N°	€
250	10	45	20266-250	131,53
300	12	55	20266-300	186,13

20275

Pince-Étau Becs Coudés sans Coupe

Inox

Aisi 420

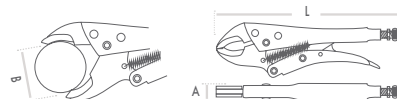

L mm	L"	B mm	A mm	Part N°	€
225	9	30	12	20275-225	138,66

Inox

Pinces INOX

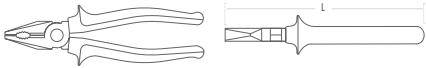

20205

Pince Universelle

Inox

Aisi 420



L mm	L"	Part N°	€
160	6	20205-160	55,83
180	7	20205-180	69,93
200	8	20205-200	89,23

20212

Pince Coupante Diagonale

Inox

Aisi 420



L mm	L"	Part N°	€
160	6	20212-160	59,92
200	8	20212-200	65,23

20213

Pince Coupante Diagonale Renforcée

Inox

Aisi 420



L mm	L"	Part N°	€
200	8	20213-200	90,44

20208

Pince Demi-Ronde à Becs Longs Droits avec Coupe

Inox

Aisi 420



L mm	L"	Part N°	€
160	6	20208-160	60,29
200	8	20208-200	69,57

20210

3 Pinces Trousse Nylon

3

Pcs

Inox

Aisi 420



180 mm

160 mm

160 mm

Part N°	€
20210-002	190,14



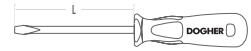

20331

Electricien

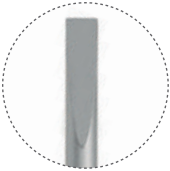

Inox

Aisi 420



A mm	L mm	Part N°	€
3	75	20331-030-075	7,97
4	75	20331-040-075	10,47
5	100	20331-050-100	15,67
6	100	20331-060-100	21,97
8	150	20331-080-150	22,05

20334

Phillips



Inox

Aisi 420



Icon	L mm	Part N°	€
PH1	75	20334-PH1-075	15,42
PH2	100	20334-PH2-100	21,15
PH3	150	20334-PH3-150	23,53

20330

Coffret Plastique

5

Pcs



Inox

Aisi 420



Recta



PH1 • PH2



Part N°	€
20330-002	84,67

Embouts de Vissage INOX

1/4" • 30 mm

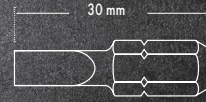

20400

Phillips



Aisi 420



		Part N°	€/
PH1	5	20400-PH1-5	17,62
PH2	5	20400-PH2-5	17,62
PH3	5	20400-PH3-5	17,62

20401

Pozidriv



Aisi 420



		Part N°	€/
PZ1	5	20401-PZ1-5	17,62
PZ2	5	20401-PZ2-5	17,62
PZ3	5	20401-PZ3-5	17,62

20402

Plat



Aisi 420

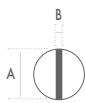

A mm	B mm		Part N°	€/
4	0,8	5	20402-040-5	18,65
5,5	1	5	20402-055-5	18,65
6,5	1,2	5	20402-065-5	18,65

20403

Torx



Aisi 420



		Part N°	€/
T10	5	20403-T10-5	19,88
T15	5	20403-T15-5	19,88
T20	5	20403-T20-5	19,88
T25	5	20403-T25-5	19,88
T30	5	20403-T30-5	19,88
T40	5	20403-T40-5	19,88

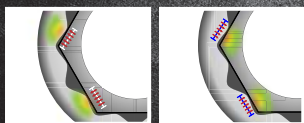

• Sur la clé

• Sur le boulon

Clés Fixes

Clés Mixtes INOX

20451

Clé Mixte

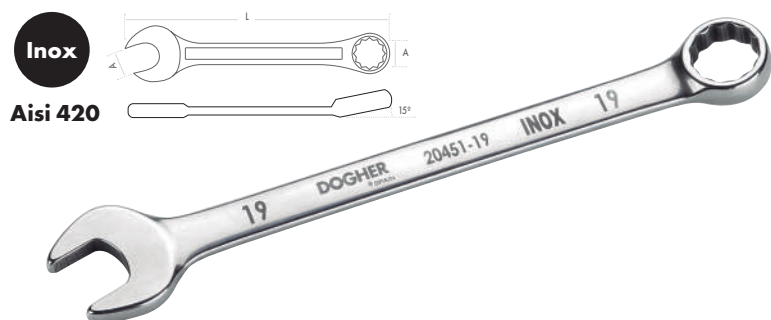

A mm	L mm	Part N°	€
8	120	20451-08	18,80
10	140	20451-10	19,66
11	150	20451-11	22,07
12	160	20451-12	23,26
13	170	20451-13	23,98
14	180	20451-14	25,20
15	190	20451-15	26,17
17	210	20451-17	29,07
19	230	20451-19	34,55

20451

Présentoir Plastique

6

Pcs

Inox

Aisi 420

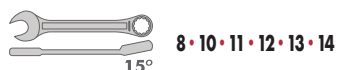

Part N°	€
20451-016	132,96

8

Pcs

Inox

Aisi 420



Part N°	€
20451-018	196,58

20451

Étui Carton

5

Pcs

Inox

Aisi 420



Part N°	€
20451-035	107,76

6

Pcs

Inox

Aisi 420



Part N°	€
20451-036	132,96

8

Pcs

Inox

Aisi 420



Part N°	€
20451-038	196,58

Inox

Clés à Molette, Clés en "T" et Clés Mâles INOX



20493

Clé à Molette Professionnelle

Inox

Aisi 420

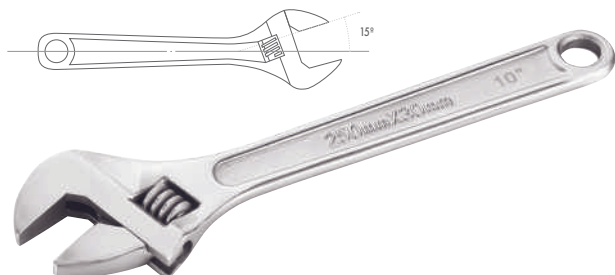

L mm	L "	mm	Part N°	€
100	4	15	20493-100	76,93
150	6	20	20493-150	89,07
200	8	25	20493-200	116,51
250	10	30	20493-250	144,25
300	12	36	20493-300	178,63
375	15	47	20493-375	225,72
450	20	60	20493-450	272,13

20618

Hexagonale



Inox

Aisi 420

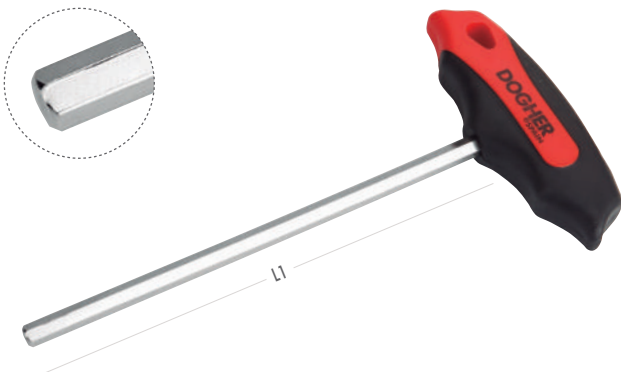

mm	L1 mm	Part N°	€
2	90	20618-02	13,16
2,5	100	20618-02,5	13,28
3	115	20618-03	14,02
4	120	20618-04	15,89
5	140	20618-05	18,49
6	160	20618-06	22,33
8	175	20618-08	29,41
10	200	20618-10	36,60

20605

Hexagonale Extra Longue
Tête Sphérique



Inox

Aisi 420



mm	L1 mm	L2 mm		Part N°	€
1,5	90	14	10	20605-01,5	6,38
2	100	15	10	20605-02	6,66
2,5	112	18	10	20605-02,5	8,22
3	126	20	10	20605-03	10,20
4	142	25	10	20605-04	10,69
5	160	28	10	20605-05	12,33
6	180	32	10	20605-06	12,66
8	200	36	5	20605-08	16,28
10	224	40	5	20605-10	18,91

20608

Torx Longue



Inox

Aisi 420

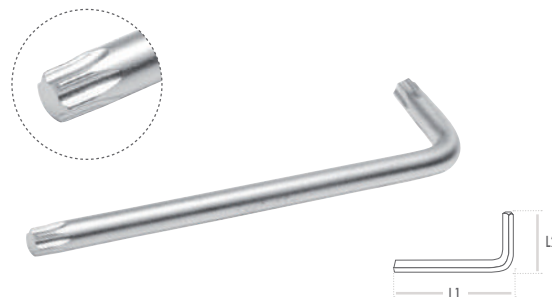

mm	L1 mm	L2 mm		Part N°	€
T10	86	17	10	20608-T10	11,16
T15	90	18	10	20608-T15	12,18
T20	95	19	10	20608-T20	12,19
T25	100	20	10	20608-T25	12,54
T27	105	21	5	20608-T27	13,65
T30	114	24	5	20608-T30	13,90
T40	124	26	5	20608-T40	14,65
T45	137	29	5	20608-T45	15,16
T50	152	32	5	20608-T50	18,07

20531

Hexagonale



Aisi 420



mm	L mm	Part N°	€
8	38	20531-08	39,77
10	38	20531-10	41,08
11	38	20531-11	41,73
12	38	20531-12	43,03
13	38	20531-13	45,08
14	38	20531-14	48,90
17	38	20531-17	52,84
19	38	20531-19	58,12

20544

Cliquet



Aisi 420



L mm	Part N°	€
245	20544-001	144,69

20531

Hexagonale

8

Pcs

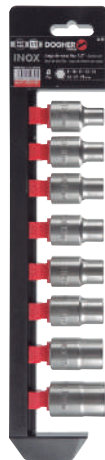

8 • 10 • 11 • 12 • 13 • 14 • 17 • 19

Part N°	€
20531-051	370,53

20531

Hexagonale et Cliquet

9

Pcs



72 dents

8 • 10 • 11 • 12 • 13 • 14 • 17 • 19

Part N°	€
20531-062	515,22

Inox

Marteaux INOX



20701

Marteau Mécanicien Tête Boule
Manche Fibre de Verre

Inox

Aisi 420



g	L mm	Part N°	€
230	285	20701-230	34,97
340	285	20701-340	47,03
450	300	20701-450	50,64
680	325	20701-680	90,44
910	355	20701-910	104,91
1130	370	20701-1130	119,37

20705

Massette de Maçon
Manche Fibre de Verre

Inox

Aisi 420



g	L mm	Part N°	€
1000	390	20705-1000	102,49
1500	395	20705-1500	144,69
2000	400	20705-2000	185,68
2500	745	20705-2500	233,92
3000	745	20705-3000	277,33
3600	750	20705-3600	331,58