

# DOGHER

® TOOLS

*Making Solutions*



	476
	477
	482
	483
	484
	486
	488

	491
	492
	493
	495 496

## Varied Tools 900

# Varied Tools

## Nut Splitter



901

### Professional Nut Splitter



mm	Part N°	€
3 ~ 12 mm	901-03-12	38,56
12 ~ 16 mm	901-12-16	45,02
16 ~ 22 mm	901-16-22	55,65

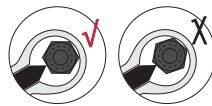

- Splits nut up without damaging the thread.
- Place the nut splitter as indicated in the drawing for a correct use of the tool.

905

### Threaded Pin Extractor with Sliding Hammer Shaft M3-M4-M5-M6-M8-M10

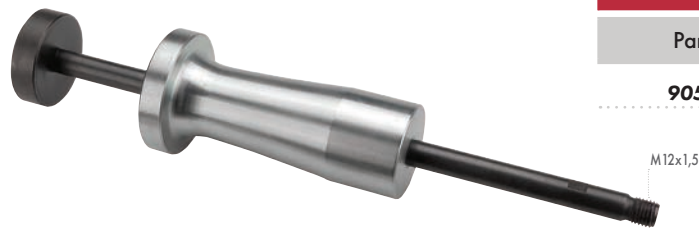

Part N°	€
905-150	157,25



905

### Threaded Inserts

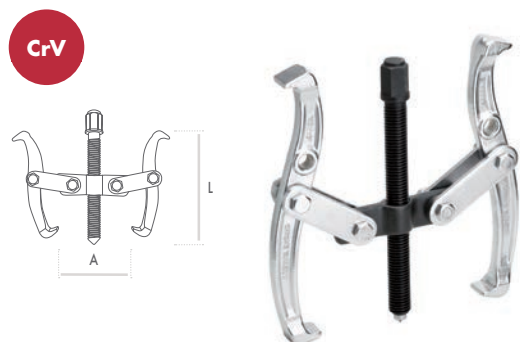

Threaded	Part N°	€
M3	905-103	13,63
M4	905-104	13,63
M5	905-105	13,63
M6	905-106	13,63
M8	905-108	13,63
M10	905-110	13,63

**902**
**Reversible 2 Arm Gear Puller**

L mm	L"	A min-A max	Thread	Max. tension (KN)	Part N°	€
<b>75</b>	3"	15-80	Tr 12x2	11	<b>902-075</b>	<b>46,64</b>
<b>100</b>	4"	20-110	Tr 14x2,5	18	<b>902-100</b>	<b>54,92</b>
<b>150</b>	6"	25-160	Tr 17x2,5	30	<b>902-150</b>	<b>73,58</b>
<b>200</b>	8"	30-210	Tr 21x2,5	50	<b>902-200</b>	<b>134,14</b>
<b>300</b>	12"	50-310	Tr 30x4	98	<b>902-300</b>	<b>289,12</b>

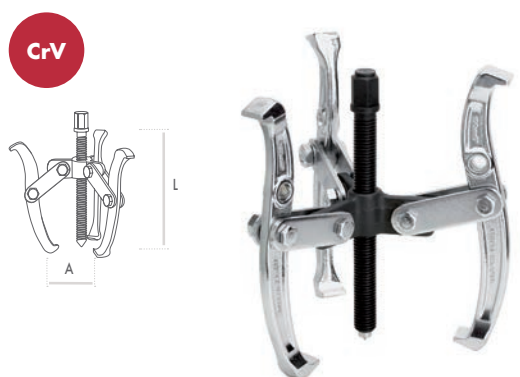
**903**
**Reversible 3 Arm Gear Puller**

L mm	L"	A min-A max	Thread	Max. tension (KN)	Part N°	€
<b>75</b>	3"	15-80	Tr 12x2	16	<b>903-075</b>	<b>55,97</b>
<b>100</b>	4"	20-110	Tr 14x2,5	26	<b>903-100</b>	<b>65,90</b>
<b>150</b>	6"	25-160	Tr 17x2,5	44	<b>903-150</b>	<b>88,28</b>
<b>200</b>	8"	30-210	Tr 21x2,5	70	<b>903-200</b>	<b>160,95</b>
<b>300</b>	12"	50-310	Tr 30x4	110	<b>903-300</b>	<b>423,62</b>

**900/902/903**
**Gear Puller Spare Parts**

L mm	L"	Arm		Spindle		Suitable for	L mm	L"	Body		Suitable for
		Part N°	€/u.	Part N°	€				Part N°	€	
<b>75</b>	3"	<b>900-075G</b>	<b>23,32</b>	<b>900-075H</b>	<b>14,00</b>	<b>902-075 / 903-075</b>	<b>75</b>	3"	<b>902-075C</b>	<b>9,32</b>	<b>902-075</b>
<b>100</b>	4"	<b>900-100G</b>	<b>27,46</b>	<b>900-100H</b>	<b>16,47</b>	<b>902-100 / 903-100</b>	<b>100</b>	4"	<b>902-100C</b>	<b>10,98</b>	<b>902-100</b>
<b>150</b>	6"	<b>900-150G</b>	<b>29,43</b>	<b>900-150H</b>	<b>22,07</b>	<b>902-150 / 903-150</b>	<b>150</b>	6"	<b>902-150C</b>	<b>14,72</b>	<b>902-150</b>
<b>200</b>	8"	<b>900-200G</b>	<b>46,95</b>	<b>900-200H</b>	<b>40,24</b>	<b>902-200 / 903-200</b>	<b>200</b>	8"	<b>902-200C</b>	<b>26,83</b>	<b>902-200</b>
<b>300</b>	12"	<b>900-300G</b>	<b>115,65</b>	<b>900-300H</b>	<b>57,82</b>	<b>902-300 / 903-300</b>	<b>300</b>	12"	<b>902-300C</b>	<b>52,04</b>	<b>902-300</b>

L mm	L"	Body		Suitable for
		Part N°	€	
<b>75</b>	3"	<b>903-075C</b>	<b>11,19</b>	<b>903-075</b>
<b>100</b>	4"	<b>903-100C</b>	<b>13,18</b>	<b>903-100</b>
<b>150</b>	6"	<b>903-150C</b>	<b>17,66</b>	<b>903-150</b>
<b>200</b>	8"	<b>903-200C</b>	<b>32,19</b>	<b>903-200</b>
<b>300</b>	12"	<b>903-300C</b>	<b>84,72</b>	<b>903-300</b>

# Varied Tools

## Gear Pullers



904

### Reversible Universal 2 Arm Gear Puller

CrV

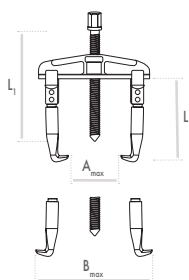

A min-A max	B min-Bmax	L	Thread	L <sub>1</sub>	Max. tension (KN)	Part N°	€
<b>30-90</b>	70-130	100	M14x1,5	130	30	<b>904-90-100</b>	<b>79,36</b>
<b>35-130</b>	80-180	100	M14x1,5	130	30	<b>904-130-100</b>	<b>80,70</b>
<b>40-160</b>	105-220	150	M20x2	210	42	<b>904-160-150</b>	<b>133,84</b>
<b>40-200</b>	120-270	150	M20x2	210	42	<b>904-200-150</b>	<b>184,28</b>
<b>60-250</b>	160-330	205	M27x2	280	60	<b>904-250-200</b>	<b>336,26</b>
<b>60-350</b>	160-420	205	M27x2	280	60	<b>904-350-200</b>	<b>367,36</b>
<b>90-520</b>	195-600	205	M27x2	280	60	<b>904-520-200</b>	<b>629,55</b>

904

### Gear Puller Spare Parts

L mm	L"	Arm		Spindle		Suitable for
		Part N°	€/u.	Part N°	€	
<b>100</b>	4"	<b>904-001G</b>	<b>31,74</b>	<b>904-001H</b>	<b>23,80</b>	<b>904-90-100 / 904-130-100</b>
<b>150</b>	6"	<b>904-002G</b>	<b>53,54</b>	<b>904-002H</b>	<b>40,15</b>	<b>904-160-150 / 904-200-150</b>
<b>200</b>	8"	<b>904-003G</b>	<b>134,51</b>	<b>904-003H</b>	<b>67,25</b>	<b>904-250-200 / 904-350-200 / 904-520-200</b>

L mm	L"	Body		
		Part N°	€	Suitable for
<b>100</b>	4"	<b>904-90-100C</b>	<b>31,74</b>	<b>904-90-100</b>
<b>100</b>	4"	<b>904-130-100C</b>	<b>33,89</b>	<b>904-130-100</b>
<b>150</b>	6"	<b>904-160-150C</b>	<b>53,54</b>	<b>904-160-150</b>
<b>150</b>	6"	<b>904-200-150C</b>	<b>73,71</b>	<b>904-200-150</b>
<b>200</b>	8"	<b>904-250-200C</b>	<b>94,15</b>	<b>904-250-200</b>
<b>200</b>	8"	<b>904-350-200C</b>	<b>110,21</b>	<b>904-350-200</b>
<b>200</b>	8"	<b>904-520-200C</b>	<b>346,25</b>	<b>904-520-200</b>

**Gear Pullers**

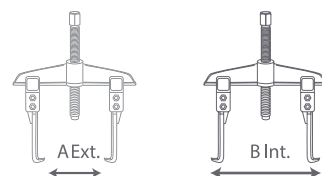

**905**

Multiple 2 arm gear puller

CrV

100 mm

200 mm

250 mm



L mm	A min-A max	B min-B max	Part N°	€
<b>100-250</b>	30-140	55-170	<b>905-001</b>	<b>265,91</b>

Body	
Part N°	€
<b>905-001C</b>	<b>79,77</b>

Spindle	
Part N°	€
<b>905-001H</b>	<b>53,18</b>

		Arm	
L mm	L"	Part N°	€/u.
<b>100</b>	4"	<b>905-001G1</b>	<b>45,20</b>
<b>200</b>	8"	<b>905-001G2</b>	<b>55,84</b>
<b>250</b>	10"	<b>905-001G3</b>	<b>74,46</b>

**905**

Multiple 3 arm gear puller

CrV

100 mm

200 mm

250 mm



L mm	A min-A max	B min-B max	Part N°	€
<b>100-250</b>	30-140	70-170	<b>905-002</b>	<b>381,11</b>

Body	
Part N°	€
<b>905-002C</b>	<b>95,28</b>

Spindle	
Part N°	€
<b>905-001H</b>	<b>53,18</b>

		Arm	
L mm	L"	Part N°	€/u.
<b>100</b>	4"	<b>905-001G1</b>	<b>45,20</b>
<b>200</b>	8"	<b>905-001G2</b>	<b>55,84</b>
<b>250</b>	10"	<b>905-001G3</b>	<b>74,46</b>



# Varied Tools

## Gear Pullers



**905**

Multiple 3 arm gear puller

CrV

200  
mm

300  
mm



M20x2



L mm	A min-A max	B min-B max	Part N°	€
<b>200-300</b>	40-220	110-270	<b>905-003</b>	<b>471,48</b>

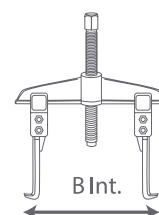
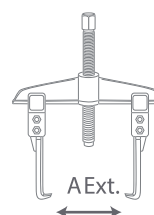

Body	
Part N°	€
<b>905-003C</b>	<b>127,30</b>

Spindle	
Part N°	€
<b>905-003H</b>	<b>94,30</b>

		Arm	
L mm	L"	Part N°	€/u.
<b>200</b>	8"	<b>905-003G2</b>	<b>99,02</b>
<b>250</b>	10"	<b>905-003G3</b>	<b>108,44</b>

**905**

Multiple 2 & 3 arm gear puller

CrV

100  
mm

200  
mm

250  
mm



905-001

905-002



905-001



905-002

L mm	A min-A max	B min-B max	Part N°	€
<b>100-250</b>	30-140	55-170	<b>905-004</b>	<b>458,81</b>

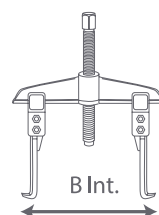
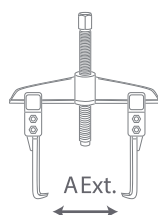

Body	Part N°	€
	<b>905-001C</b>	<b>79,77</b>
	<b>905-002C</b>	<b>95,28</b>

Spindle	Part N°	€
	<b>905-001H</b>	<b>53,18</b>

		Arm	
L mm	L"	Part N°	€/u.
<b>100</b>	4"	<b>905-001G1</b>	<b>45,20</b>
<b>200</b>	8"	<b>905-001G2</b>	<b>55,84</b>
<b>250</b>	10"	<b>905-001G3</b>	<b>74,46</b>

# Varied Tools

## Separator Pullers



905

Separator puller tools set

CrV

30-50  
mm

50-75  
mm

min-max	Part N°	€
30-75	905-005	266,29



905

Separator puller tool

CrV

30-50  
mm



min-max	Part N°	€
30-50	905-006	54,23

905

Guillotine Puller



Part N°	€
905-600	59,51

Suitable with 905-006

905

Separator puller tool

CrV

50-75  
mm



min-max	Part N°	€
50-75	905-007	73,17

905

Guillotine Puller



Part N°	€
905-700	59,51

Suitable with 905-007

905

Separator puller tool

CrV

75-105  
mm



min-max	Part N°	€
75-105	905-008	98,29

905

Guillotine Puller



Part N°	€
905-800	126,72

Suitable with 905-008

905

Separator puller tool

CrV

100-150  
mm



min-max	Part N°	€
100-150	905-009	277,76

905

Guillotine Puller



Part N°	€
905-900	130,43

Suitable with 905-009



**Gear Pullers**

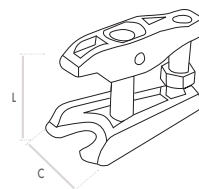

**905**

Universal ball joint separator

Cr-V

12-50  
mm

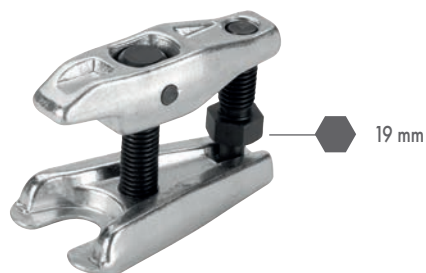

L min-max	C min-max	Part N°	€
<b>12-50</b>	18-22	<b>905-010</b>	<b>31,15</b>

**905**

Ball joint separator

Cr-V

12-50  
mm

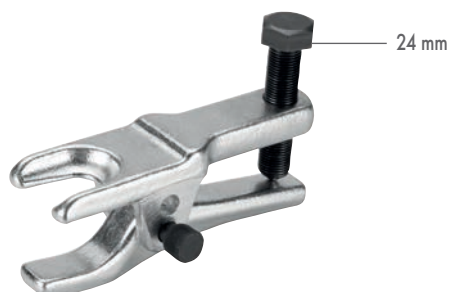

min-max	C	Part N°	€
<b>12-50</b>	20	<b>905-011</b>	<b>60,73</b>

**905**

Ball joint separator

Cr-V

60-80  
mm



min-max	C	Part N°	€
<b>60-80</b>	20	<b>905-012</b>	<b>78,91</b>

**905**

3 Adjustable Jaws Oil Filter Wrench



Ø mm	Part N°	€
<b>65-120</b>	<b>905-020</b>	<b>20,33</b>

# Varied Tools

## Caulking Guns

- Structure and Handle in Aluminium
- Pushing Force 1500N
- Reinforced Cartridge Holder 11 mm
- Advance / Pulse 10 mm
- Cartridge Plunger 7.9 mm



914

Triple Barrel Caulking Gun

- 225 mm
- Al
- 1500 NW
- 9"



L mm	Ø mm	Part N°	€
225	78	914-225	35,03



915

Caulking Gun With Spout Cutter

- 225 mm
- Al
- 1500 NW
- 9"
- 360°



L mm	Ø mm	Part N°	€
225	57	915-225	24,53



916

Fast Recoil Caulking Gun

- 225 mm
- Al
- 1500 NW
- 9"
- 360°



L mm	Ø mm	Part N°	€
225	55	916-225	22,28

917

Caulking Gun

- 225 mm
- Al
- 4000 NW
- 25:1
- 9"
- 360°



L mm	Ø mm	Part N°	€
225	55	917-225	37,13

**912**

Caulking Gun Aluminium Handle

Ø mm  
**50**



L mm	Ø mm	Part N°	€
<b>225</b>	55	<b>912-225</b>	<b>21,89</b>
<b>250</b>	55	<b>912-250</b>	<b>23,18</b>
<b>360</b>	55	<b>912-325</b>	<b>27,68</b>



**910**

Steel Body Caulking Gun

Ø mm  
**50**



L mm	Ø mm	Part N°	€
<b>225</b>	50	<b>910-225</b>	<b>7,17</b>
<b>250</b>	50	<b>910-250</b>	<b>7,48*</b>

\* Until end of stock

**911**

Caulking Gun Zinc Handle

Ø mm  
**50**



L mm	Ø mm	Part N°	€
<b>225</b>	50	<b>911-225</b>	<b>10,02</b>

# Varied Tools

## Foam & Mortar Caulking Guns

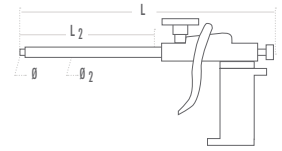

**913**

Aluminium Body Mortar Caulking Gun

Ø mm  
**50**

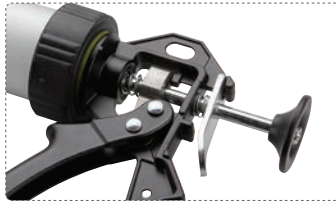

L mm	Ø mm	Part N°	€
<b>225</b>	50	<b>913-225</b>	<b>24,83</b>
<b>300</b>	50	<b>913-300</b>	<b>25,92</b>
<b>375</b>	50	<b>913-375*</b>	<b>29,58</b>

- \* Capacity 600cm<sup>3</sup> / cartridge
- \* Reinforced plunger arm.

### Mortar Caulking Gun Accessories

**913**

Mortar Caulking Gun Spare Nozzles

**2**  
Pcs

Suitable for  
**913**



Part N°	€/ 2Pcs
<b>913-001</b>	<b>1,85</b>

**914**

Foam Gun Pro

Ø mm  
**11**



L mm	L <sub>2</sub> mm	Ø mm	Ø <sub>2</sub> mm	Part N°	€
<b>325</b>	190	11	14	<b>914-001</b>	<b>41,63</b>

- \* Reinforced body. Application frame and plunger arm are inner and outer Teflon coated to ensure a longer lifetime.

**914**

Foam Gun

Ø mm  
**11**



L mm	L <sub>2</sub> mm	Ø mm	Ø <sub>2</sub> mm	Part N°	€
<b>325</b>	180	11	12	<b>914-002</b>	<b>31,41</b>

**915**

Rigid Hose Grease Pump

**10.000  
PSI**



- Air Release Valve
- Bulk Charge

1/8 BSP



Bulk cc	Container gr	L Pump	Ø Pump	L Hose	Ø Hose	Part N°	€
500	400	380	57,5	190	9,5	<b>915-010</b>	<b>58,01</b>

**915**

Flexible Hose Grease Pump

**3.000  
PSI**

1/8 BSP



**915-020**

**8.000  
PSI**

1/8 BSP



**915-030**



- Air Release Valve
- Bulk Charge

Bulk cc	Container gr	L Pump	Ø Pump	L Hose	Ø Hose	Part N°	€
-	-	330	51,5	300	8,5	<b>915-020</b>	<b>35,03</b>
500	400	350	57,5	300	8,5	<b>915-030</b>	<b>38,18</b>

**915**

Flexible Hose for Pump

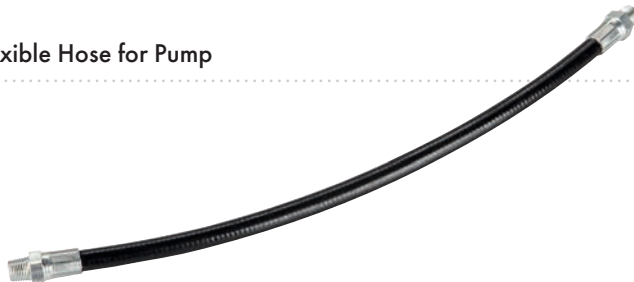

L mm	Part N°	€
<b>300</b>	<b>915-021</b>	<b>7,73</b>

**915**

Rigid Hose for Pump



L mm	Part N°	€
<b>190</b>	<b>915-022</b>	<b>7,73</b>



# Varied Tools

## Rivet Guns



**918**

### Professional Rivet Gun

- Replaceable nozzle head
- 4 heads are included  $\varnothing$  2,4-3,2-4-4,8 mm.
- Spring loaded handle ejects rivets stem
- Comfortable anti slip handle



Part N°	€
918-010	41,78

**918**

### Interchangeable Head Set

- 4 interchangeable heads for rivet gun Ref. 918-010
- Included 1 x  $\varnothing$  2,4-3,2-4-4,8 mm



Part N°	€
918-1	4,39

**918**

### Automatic Riveter

**4 in 1**

- Replaceable nozzle head
- 4 heads are included  $\varnothing$  2,4-3,2-4-4,8 mm.
- Spring loaded handle ejects rivets stem
- Comfortable anti slip handle



Part N°	€
918-012	36,42

**919**

### Two Hands Rivet

- Hard Metal Clamps
- Internal Force Multiplier
- Ergonomic Handle
- Aluminium Body
- for  $\varnothing$  2,4-3,2-4-4,8-6,4 mm rivets
- $\varnothing$  2,4-3,2-4-4,8 mm Stainless Steel rivets



L mm	L"	Part N°	€
320	13	919-016	77,09

**919**

### Interchangeable Heads & Clamp



Clamp		Heads		
Part N°	€	L mm	Part N°	€
919-016M	12,86	2,4	919-016-024	11,68
		3,2	919-016-032	11,68
		4,0	919-016-040	11,68
		4,8	919-016-048	11,68
		6,4	919-016-064	11,68

919

Multifunction Hand Rivet



3 en 1

Part N°	€
919-020	148,76



2,4	3,2	4,0	4,8	6,4 mm	M3	M4	M5	M6	M8	M10

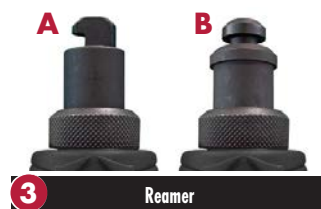

919

Hand Rivet Spare Parts

Clamp	
Part N°	€
919-020M	12,98

Reamer	
Part N°	€
919-020-EA	21,26
919-020-EB	21,26

Heads		
L mm	Part N°	€
2,4	919-020-024	12,62
3,2	919-020-032	12,62
4,0	919-020-040	12,62
4,8	919-020-048	12,62
6,4	919-020-064	12,62

Heads		
M	Part N°	€
M3	919-020-M3	20,33
M4	919-020-M4	20,33
M5	919-020-M5	20,33
M6	919-020-M6	20,33
M8	919-020-M8	20,33
M10	919-020-M10	20,33

919

One Hand Nut Riveter

- Replaceable nozzle head
- 4 heads are included M3-M4-M5-M6.



L mm	L"	Part N°	€
210	8	919-022	95,81

# Varied Tools

## Rivet Guns



919

Hand Nut Riveter

410  
mm

16"

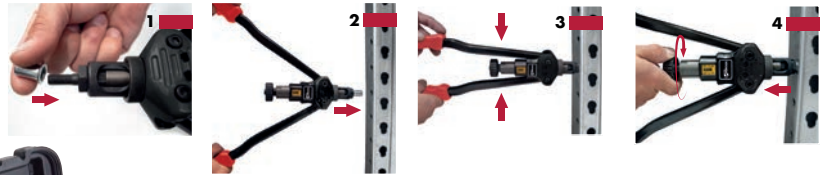

L mm	L"	Part N°	€
410	16	919-025	124,20

- Special for intensive works.
- Ergonomic hand nut riveter for reduced effort.
- Easy components replacement.
- Includes multifunctional key
- 7 heads are included M3-M4-M5-M6-M8-M10-M12.



919

Interchangeable Heads

M	Part N°	€
M3	919-025-M3	18,11
M4	919-025-M4	18,11
M5	919-025-M5	18,11
M6	919-025-M6	18,11
M8	919-025-M8	18,11
M10	919-025-M10	18,11
M12	919-025-M12	18,11

919

Hand Nut Riveter

- Replaceable nozzle head
- 7 heads are included M3-M4-M5-M6-M8-M10-M12.



L mm	L"	Part N°	€
350	14	919-026	152,51

919

Interchangeable Heads

M	Part N°	€
M3	919-025-M3	18,11
M4	919-025-M4	18,11
M5	919-025-M5	18,11
M6	919-025-M6	18,11
M8	919-025-M8	18,11
M10	919-025-M10	18,11
M12	919-025-M12	18,11

**945** Suction Cup



Ø mm	Capacity	Part N°	€
115	50 kg	945-001	19,41

- Aluminium structure.
- One-handed use.
- Automotive and transport applications.
- To be used in smooth and non-porous surfaces.

**945** Suction Cup



Ø mm	Capacity	Part N°	€
115	100 kg	945-002	38,82

- Aluminium structure Double.
- Automotive and transport applications.
- To be used in smooth and non-porous surfaces.

**945** Double Articulated Suction Cup Special for Curved Surfaces



Ø mm	Capacity	Part N°	€
118	80 kg	945-005	46,60

- Two plates structure
- Articulated handle, it allows the adjustment to curved surfaces
- Special for car maintenance, installing and uninstalling of car sheets and windshields

**945** Suction Cup



Ø mm	Capacity	Part N°	€
115	130 kg	945-003	53,70

- Aluminium structure Triple.
- Automotive and transport applications.
- To be used in smooth and non-porous surfaces.

**945** Suction Cup



Ø mm	Capacity	Part N°	€
203	180 kg	945-004	102,25

- High resistance suction cup. Including a priming pump.
- Vacuum monitored through the pressure gauge.
- Valve to release pressure.
- For curved and structured surfaces.



# Varied Tools

## Suction Cups, Mirror & Punches



945

Suction Cup Special for Windshields



Ø mm	Capacity	Part N°	€
230	200 kg	945-006	176,94

- One plate structure
- Special for curved surfaces mainly windshields



930

Telescopic Inspection Mirror

Inox

- Industrial quality mirror suitable for inspection in space limited areas
- Telescopic mirror. Gathered: 240 mm. Extended: 930 mm
- Double flexible head provides vision at any angle
- Anti slip rubber handle

360°



L min-max	Part N°	€
240-930	930-001	16,17



940

Professional Punch Plier



- Clean and precise holes in leather, thin plastic, paper, cloth,...
- ø 2-2,5-3-3,5-4-4,5 mm
- Ergonomic red dipped PVC handle



Part N°	€
940-001	23,77

940

Slogging Hole Punch



- Anti-slipping knurling handle
- ø 2-2,5-3-3,5-4-4,5 mm



Part N°	€
940-002	21,61



**925**

Cylindrical Bench Vice

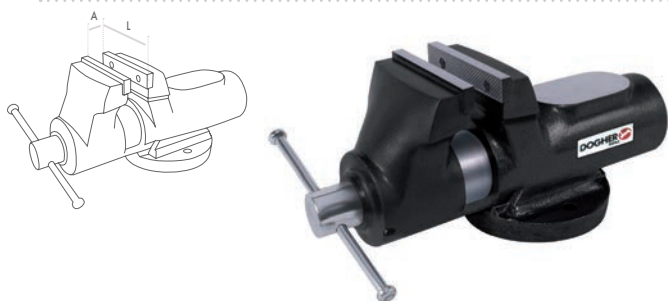

**926**

Square Guided Bench Vice

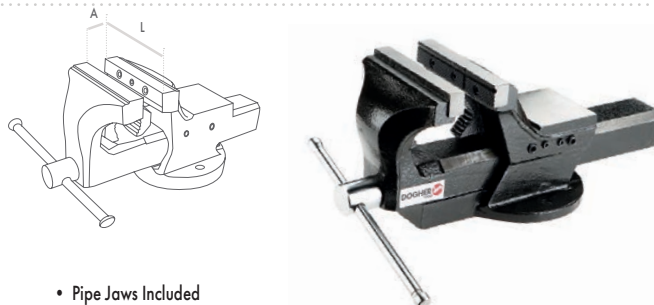

• Pipe Jaws Included

L mm	A mm	Kg	Part N°	€
<b>100</b>	105	13	<b>925-100</b>	<b>339,42</b>
<b>125</b>	130	22	<b>925-125</b>	<b>467,36</b>
<b>150</b>	165	32	<b>925-150</b>	<b>667,33</b>

L mm	A mm	Kg	Part N°	€
<b>100</b>	105	7,5	<b>926-100</b>	<b>226,98</b>
<b>125</b>	155	14	<b>926-125</b>	<b>252,93</b>
<b>150</b>	165	19	<b>926-150</b>	<b>365,18</b>
<b>175</b>	205	26	<b>926-175</b>	<b>578,33</b>

**925R**

Spare Jaws

Suitable for  
**925**



**926R**

Spare Jaws

Suitable for  
**926**

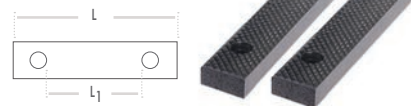

L mm	L1 mm	Part N°	€ / 2Pcs
<b>100</b>	53	<b>925R-100</b>	<b>27,74</b>
<b>125</b>	73	<b>925R-125</b>	<b>41,06</b>
<b>150</b>	88	<b>925R-150</b>	<b>50,23</b>

L mm	L1 mm	Part N°	€ / 2Pcs
<b>100</b>	24	<b>926R-100</b>	<b>33,41</b>
<b>125</b>	28	<b>926R-125</b>	<b>39,42</b>
<b>150</b>	43	<b>926R-150</b>	<b>45,00</b>
<b>175</b>	53	<b>926R-175</b>	<b>50,38</b>

**925B**

Revolving Base

Suitable for  
**925**



**926B**

Revolving Base

Suitable for  
**926**



L mm	Part N°	€
<b>100</b>	<b>925B-100</b>	<b>33,98</b>
<b>125</b>	<b>925B-125</b>	<b>38,18</b>
<b>150</b>	<b>925B-150</b>	<b>54,98</b>

L mm	Part N°	€
<b>100</b>	<b>926B-100</b>	<b>32,98</b>
<b>125</b>	<b>926B-125</b>	<b>35,36</b>
<b>150</b>	<b>926B-150</b>	<b>45,42</b>
<b>175</b>	<b>926B-175</b>	<b>71,72</b>

## Varied Tools

Professional Bench Vices & Adjustable Jaws Oil Filter Wrench



927

Baby Vice

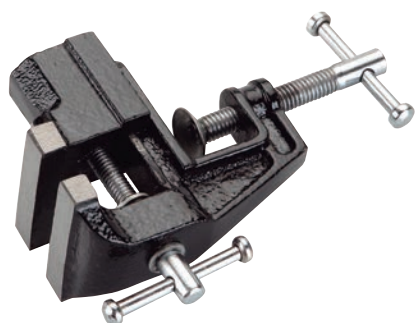

L mm	Part N°	€
50	927-050	18,90



927

Baby Vice with Swivel Base

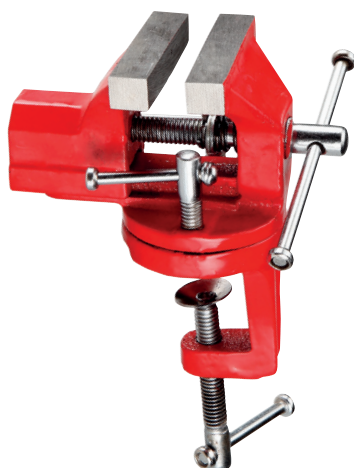

L mm	Part N°	€
90	927-060	33,86

- Maximum Opening: 40 mm

**Progressive Blow Guns**

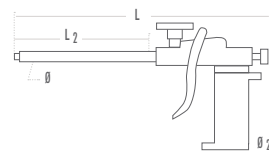

**914**

Progressive Blow Gun

Ø mm  
**8**



L mm	L <sub>2</sub> mm	Ø mm	Ø <sub>2</sub> mm	Part N°	€
<b>210</b>	100	8	1/4" G (BSP)	<b>914-010</b>	<b>19,32</b>

- Maximum air pressure: 12 Bar · 175 PSI · 1,2 Mpa
- Nozzle with metal reinforcement.
- Body manufactured of High performance POM

**914**

Progressive Blow Gun

Ø mm  
**8**



L mm	L <sub>2</sub> mm	Ø mm	Ø <sub>2</sub> mm	Part N°	€
<b>306</b>	202	8	1/4" G (BSP)	<b>914-015</b>	<b>22,66</b>

- Maximum air pressure: 12 Bar · 175 PSI · 1,2 Mpa
- Nozzle with metal reinforcement.
- Body manufactured of High performance POM

**914**

Progressive Blow Gun

Ø mm  
**8**



L mm	L <sub>2</sub> mm	Ø mm	Ø <sub>2</sub> mm	Part N°	€
<b>212</b>	93	8	1/4" G (BSP)	<b>914-020</b>	<b>24,48</b>

- Low noise level
- Maximum air pressure: 12 Bar · 175 PSI · 1,2 Mpa
- Nozzle with metal reinforcement.
- Body manufactured of High performance POM
- Manufactured under OSHA norm.  
Occupational Safety and Health Administration.



# Varied Tools

## Punch Crafts



### INTERCHANGEABLE HOLLOW PUNCH:

The new Hollow Punch XTREME allows the operator to conduct high precision holes to achieve seals, washers, etc.

Due to FASCTlick thread systems the changes of shaft and punch holes are fast.

- The holes from 2 to 10mm diameter are joined to the Hollow Punch through internal thread M13x1.
- The holes from 11 to 60mm diameter are joined to the Hollow Punch through FASTClick system.
- The 940-250M and 940-260M shafts are joined to the 940-02-60 Hollow Punch through M20x1.5 thread.

The use is recommended for sheets of aluminium, steel, leather, rubber, cardboard, foam, plastic, fiber...

### CUTTING CAPACITY

Steel-Aluminium and Copper sheets: 0.3 mm thickness

940

Steel Punch Craft



L mm	Ø mm	Part N°	€
120	16	940-02-10	30,91

- Hole Punches Ø 2 - 10 mm

940

Steel Punch Craft



L mm	Ø mm	Part N°	€
95	24	940-03-20	42,12

- Hole Punches Ø 2 - 20 mm

940

Bimaterial Punch Craft



L mm	Ø mm	Part N°	€
180	34,5	940-02-60	107,92

- Hole Punches Ø 2 - 60 mm

940

Bimaterial Punch Craft



L mm	Ø mm	Part N°	€
180	35	940-03-30	117,51

- Hole Punches Ø 2 - 30 mm



940

Hole Punches Spare Parts

► Holes Ø 2 - 10 mm  
Thread M13x1

Ø mm	L mm	Part N°	€
2	27	940-102	11,64
3	27	940-103	11,64
4	27	940-104	11,64
5	27	940-105	11,64
6	27	940-106	11,64
7	27	940-107	11,64
8	27	940-108	11,64
9	27	940-109	11,64
10	27	940-110	11,64

► Holes Ø 11 - 60 mm

**Fast  
Click**

Ø mm	L mm	Part N°	€
11	27	940-111	14,47
12	27	940-112	14,47
13	27	940-113	14,47
14	27	940-114	14,47
15	27	940-115	14,47
16	27	940-116	14,47
17	27	940-117	14,47
18	27	940-118	14,47
19	27	940-119	14,47
20	27	940-120	14,47
21	32	940-121	19,13
22	32	940-122	19,13
23	32	940-123	19,13
24	32	940-124	19,13
25	32	940-125	19,13
26	32	940-126	19,13
27	32	940-127	19,13
28	32	940-128	19,13
29	32	940-129	19,13
30	32	940-130	19,13
32	37	940-132	24,64
33	37	940-133	24,64
34	37	940-134	24,64
35	37	940-135	24,64
36	37	940-136	24,64
37	37	940-137	24,64
38	37	940-138	24,64
39	37	940-139	24,64
40	37	940-140	24,64
42	42	940-142	28,58
43	42	940-143	28,58
44	42	940-144	28,58
45	42	940-145	28,58
46	42	940-146	28,58
47	42	940-147	28,58
48	42	940-148	28,58
49	42	940-149	28,58
50	42	940-150	28,58
52	47	940-152	72,91
54	47	940-154	72,91
56	47	940-156	72,91
58	47	940-158	72,91
60	47	940-160	72,91





# Varied Tools

## Punch Crafts



940

Centering Point

Ø: 4,8 mm



Ø: 14 mm

L mm	Ø mm	Part N°	€
54	14	940-210	30,91

940

Compass Bar

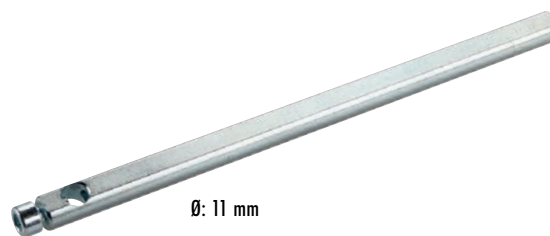

Ø: 11 mm

L mm	Ø mm	Part N°	€
420	11	940-211	18,92

940

Compass Cutter



L mm	Ø mm	Part N°	€
124	16	940-212	28,12

- Blade 940-213 included

940

Compass Cutter Blade



Part N°	€
940-213	18,67

940

Pyramidal Chuck

Part N°	€
940-250M	74,93

- To be used with Hollow Punch 940-02-60  
Included in 940-250 Set



Part N°	€
940-260M	108,17

- To be used with Hollow Punch 940-02-60  
Included in 940-260 Set



940

Steel Interchangeable Hollow Punch Set



940-03-20 Ø 2 - 20 mm



- 940-103 Ø 3
- 940-104 Ø 4
- 940-106 Ø 6
- 940-108 Ø 8
- 940-110 Ø 10



**Fast  
Click**

- 940-112 Ø 12
- 940-114 Ø 14
- 940-116 Ø 16
- 940-118 Ø 18
- 940-120 Ø 20

Part N°	€
940-320	128,33



**11  
Pcs**

940

Bi-material Interchangeable Hollow Punch Set



940-03-30 Ø 2 - 30 mm



- 940-103 Ø 3
- 940-104 Ø 4
- 940-106 Ø 6
- 940-108 Ø 8
- 940-110 Ø 10



**Fast  
Click**

- 940-112 Ø 12
- 940-114 Ø 14
- 940-116 Ø 16
- 940-118 Ø 18
- 940-120 Ø 20
- 940-122 Ø 22
- 940-124 Ø 24
- 940-126 Ø 26
- 940-128 Ø 28
- 940-130 Ø 30

Part N°	€
940-330	257,25



**16  
Pcs**

# Varied Tools

## Punch Crafts



940

Bi-material Interchangeable Hollow Punch + Pyramidal chuck + Centering Point Set



940-02-60 Ø 2 - 60 mm



940-102 Ø 2  
940-103 Ø 3  
940-104 Ø 4  
940-105 Ø 5  
940-106 Ø 6  
940-107 Ø 7  
940-108 Ø 8  
940-109 Ø 9  
940-110 Ø 10

**Fast Click**



940-112 Ø 12  
940-114 Ø 14  
940-116 Ø 16  
940-118 Ø 18  
940-120 Ø 20  
940-122 Ø 22  
940-124 Ø 24  
940-126 Ø 26  
940-128 Ø 28  
940-130 Ø 30  
940-132 Ø 32  
940-134 Ø 34  
940-136 Ø 36  
940-138 Ø 38  
940-140 Ø 40  
940-142 Ø 42  
940-144 Ø 44  
940-146 Ø 46  
940-148 Ø 48  
940-150 Ø 50



940-210



940-250M Ø 2 - 50 mm

**32**  
Pcs



Part N°	€
940-250	502,25

940

Bi-material Interchangeable Hollow Punch + Pyramidal chuck + Centering Point + Compass knife cutter with blade Set



940-02-60 Ø 2 - 60 mm



940-102 Ø 2  
940-103 Ø 3  
940-104 Ø 4  
940-105 Ø 5  
940-106 Ø 6  
940-107 Ø 7  
940-108 Ø 8  
940-109 Ø 9  
940-110 Ø 10

**Fast Click**



940-112 Ø 12  
940-114 Ø 14  
940-116 Ø 16  
940-118 Ø 18  
940-120 Ø 20  
940-122 Ø 22  
940-124 Ø 24  
940-126 Ø 26  
940-128 Ø 28  
940-130 Ø 30  
940-132 Ø 32  
940-134 Ø 34  
940-136 Ø 36  
940-138 Ø 38  
940-140 Ø 40  
940-142 Ø 42  
940-144 Ø 44  
940-146 Ø 46  
940-148 Ø 48  
940-150 Ø 50  
940-152 Ø 52  
940-154 Ø 54  
940-156 Ø 56  
940-158 Ø 58  
940-160 Ø 60



940-210



940-260M Ø 2 - 60 mm



940-213



940-212



940-211

**39**  
Pcs



Part N°	€
940-260	875,84