



DOGHER 
 TOOLS
Making Solutions

<p>25 mm 1/4"</p> 	166	<p>30 mm 75 mm 5/16"</p> 	178
<p>50 mm 90 mm 1/4"</p> 	169	<p>30 mm 75 mm 10 mm</p> 	181
<p>110 mm 125 150 mm 200 250 mm 1/4"</p> 	171		182
<p>25 mm 1/4" TiN</p> 	174		183
<p>30 mm 1/4" Bluefire</p> 	175		185
<p>50 mm 75 mm 100 150 mm 1/4"</p> 	176		

Screwdriver Bits

400

Screwdriver Bits

Forged Bit with a geometry that allows a perfect join with the screw. It offers high torsion breakage resistance.

1/4" • 25 mm

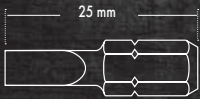

25 mm

1/4"

S2

• Indicated packaging qty is the minimum to be ordered.



400

Phillips



400

3 Screwdriver Bits Box Phillips



Logo	Qty	Part N°	€/Qty	Qty	Part N°	€/Qty
	-	-	-	10	400-PH0-10	12,86
	2	400-PH1-2	2,63	10	400-PH1-10	7,59
	2	400-PH2-2	2,63	10	400-PH2-10	7,59
	2	400-PH3-2	2,63	10	400-PH3-10	7,59
	-	-	-	10	400-PH4-10	12,86*

3 Screwdriver Bits Box



PH1 • PH2 • PH3

Part N°	€
400-001	3,28

* Until end of stock

401

Pozidriv



401

3 Screwdriver Bits Box Pozidriv



Logo	Qty	Part N°	€/Qty	Qty	Part N°	€/Qty
	-	-	-	10	401-PZ0-10	12,86
	2	401-PZ1-2	2,63	10	401-PZ1-10	7,59
	2	401-PZ2-2	2,63	10	401-PZ2-10	7,59
	2	401-PZ3-2	2,63	10	401-PZ3-10	7,59
	-	-	-	10	401-PZ4-10	12,86*

3 Screwdriver Bits Box



PZ1 • PZ2 • PZ3

Part N°	€
401-001	3,28

* Until end of stock

1/4" • 25 mm

25 mm 1/4" S2

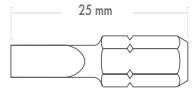

• Indicated packaging qty is the minimum to be ordered.

400 Screwdriver Displays

10 Screwdriver bit boxes



Part N°	€
400-001J	75,90

10 Screwdriver bit boxes



Part N°	€
400-002J	75,90

5 Screwdriver bit boxes



Part N°	€
400-003J	75,90

3 Screwdriver bit boxes



Part N°	€
400-004J	107,10

1 Screwdriver bit box



2 Magnetic bit holder 443-050

10 Pcs



150 x 155 x 200 mm

402 Slot

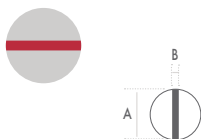

A mm	B mm		Part N°	€/
3	0,5	10	402-030-10	14,20
3,5	0,6	10	402-035-10	14,20
4	0,8	10	402-040-10	14,20
4,5	0,8	10	402-045-10	14,20
5	1	10	402-050-10	14,20
5,5	1	10	402-055-10	14,20
6	1,2	10	402-060-10	14,20
6,5	1,2	10	402-065-10	14,20
8	1,2	10	402-080-10	14,20

404 Torx Tamper



		Part N°	€/
TS10	10	404-TS10-10	26,93
TS15	10	404-TS15-10	26,93
TS20	10	404-TS20-10	26,93
TS25	10	404-TS25-10	26,93
TS27	10	404-TS27-10	26,93
TS30	10	404-TS30-10	26,93
TS40	10	404-TS40-10	26,93

Screwdriver Bits



1/4" • 25 mm

25 mm

1/4"

S2

• Indicated packaging qty is the minimum to be ordered.

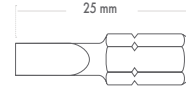

403

Torx



405

Hexagonal



		Part N°	€/		Part N°	€/
T05	-	-	-	-	403-T05-10	18,97
T06	-	-	-	-	403-T06-10	18,97
T07	-	-	-	-	403-T07-10	18,97
T08	-	-	-	-	403-T08-10	18,97
T09	-	-	-	-	403-T09-10	18,97
T10	2	403-T10-2	3,93	10	403-T10-10	14,08
T15	2	403-T15-2	3,93	10	403-T15-10	14,08
T20	2	403-T20-2	3,93	10	403-T20-10	14,08
T25	2	403-T25-2	3,93	10	403-T25-10	14,08
T27	-	-	-	-	403-T27-10	14,08
T30	2	403-T30-2	3,93	10	403-T30-10	14,08
T40	2	403-T40-2	3,93	10	403-T40-10	14,08

		Part N°	€/
HX1,5	10	405-HX015-10	14,45
HX2	10	405-HX020-10	14,45
HX2,5	10	405-HX025-10	14,45
HX3	10	405-HX030-10	14,45
HX4	10	405-HX040-10	14,45
HX5	10	405-HX050-10	14,45
HX6	10	405-HX060-10	14,45
HX8	10	405-HX080-10	17,14
HX10	10	405-HX100-10	21,73

406

Robertson



		Part N°	€/
R1	10	406-R1-10	20,20
R2	10	406-R2-10	20,20
R3	10	406-R3-10	20,20

1/4" • 50 mm

50 mm 1/4" S2

• Indicated packaging qty is the minimum to be ordered.

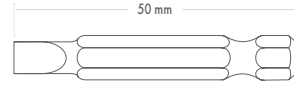

410

Phillips



50 mm

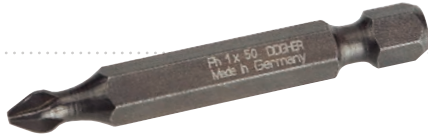

411

Pozidriv



50 mm



Icon	Part N°	€/	Part N°	€/			
	PH1	2	410-PH1-2	6,65	10	410-PH1-10	24,36
	PH2	2	410-PH2-2	6,65	10	410-PH2-10	24,36
	PH3	2	410-PH3-2	6,65	10	410-PH3-10	24,36
	PH4*	-	-	-	-	410-PH4-10	24,36*

* Until end of stock

Icon	Part N°	€/	Part N°	€/			
	PZ1	2	411-PZ1-2	6,65	10	411-PZ1-10	24,36
	PZ2	2	411-PZ2-2	6,65	10	411-PZ2-10	24,36
	PZ3	2	411-PZ3-2	6,65	10	411-PZ3-10	24,36
	PZ4*	-	-	-	-	411-PZ4-10	24,36*

* Until end of stock

412

Slot



50 mm

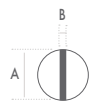

A mm	B mm	Part N°	€/	
3	0,5	10	412-030-10	37,96
3,5	0,6	10	412-035-10	37,96
4	0,8	10	412-040-10	37,96
4,5	0,8	10	412-045-10	37,96
5	1	10	412-050-10	37,96
5,5	1	10	412-055-10	37,96
6	1,2	10	412-060-10	37,96
6,5	1,2	10	412-065-10	37,96
8	1,2	10	412-080-10	37,96

413

Torx



50 mm



Icon	Part N°	€/	Part N°	€/			
	T05	-	-	-	413-T05-10	39,55	
	T06	-	-	-	413-T06-10	39,55	
	T07	-	-	-	413-T07-10	39,55	
	T08	-	-	-	413-T08-10	39,55	
	T09	-	-	-	413-T09-10	39,55	
	T10	2	413-T10-2	9,93	10	413-T10-10	40,74
	T15	2	413-T15-2	9,93	10	413-T15-10	40,74
	T20	2	413-T20-2	9,93	10	413-T20-10	40,74
	T25	2	413-T25-2	9,93	10	413-T25-10	40,74
	T27	-	-	-	413-T27-10	40,74	
	T30	2	413-T30-2	9,93	10	413-T30-10	40,74
	T40	2	413-T40-2	9,93	10	413-T40-10	40,74

Screwdriver Bits



1/4" • 50 mm

1/4" • 90 mm

50 mm 1/4" S2

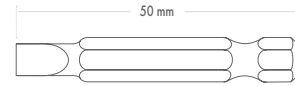

• Indicated packaging qty is the minimum to be ordered.

414

Hexagonal



50 mm



Icon	Qty	Part N°	€/Icon
	10	414-HX020-10	46,93
	10	414-HX025-10	46,93
	10	414-HX030-10	46,93
	10	414-HX040-10	46,93
	10	414-HX050-10	46,93
	10	414-HX060-10	46,93
	10	414-HX080-10	46,93

415

Robertson



50 mm



Icon	Qty	Part N°	€/Icon
	10	415-R1-10	31,50
	10	415-R2-10	31,50
	10	415-R3-10	31,50

416

Phillips



90 mm



Icon	Qty	Part N°	€/Icon
	5	416-PH1-5	35,13
	5	416-PH2-5	35,13
	5	416-PH3-5	35,13

417

Pozidriv



90 mm



Icon	Qty	Part N°	€/Icon
	5	417-PZ1-5	35,13
	5	417-PZ2-5	35,13
	5	417-PZ3-5	35,13

418

Torx



90 mm



Icon	Qty	Part N°	€/Icon
	5	418-T10-5	41,85
	5	418-T15-5	41,85
	5	418-T20-5	41,85
	5	418-T25-5	41,85
	5	418-T30-5	41,85
	5	418-T40-5	41,85

1/4" • 110 mm

110
mm

1/4"

S2

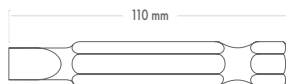

4110

Phillips



110
mm



		Part N°	€/
PH1	1	4110-PH1-1	7,24
PH2	1	4110-PH2-1	7,24
PH3	1	4110-PH3-1	7,24

4110

Pozidriv



110
mm



		Part N°	€/
PZ1	1	4110-PZ1-1	7,24
PZ2	1	4110-PZ2-1	7,24
PZ3	1	4110-PZ3-1	7,24

4110

Torx



110
mm



		Part N°	€/
T10	1	4110-T10-1	8,51
T15	1	4110-T15-1	8,51
T20	1	4110-T20-1	8,51
T25	1	4110-T25-1	8,51
T30	1	4110-T30-1	8,51
T40	1	4110-T40-1	8,51

Screwdriver Bits



1/4" • 125 mm

1/4" • 150 mm



125 mm

1/4"

S2

4125

Phillips



125 mm



		Part N°	€/
PH1	1	4125-PH1-1	7,40
PH2	1	4125-PH2-1	7,40
PH3	1	4125-PH3-1	7,40

4125

Pozidriv



125 mm



		Part N°	€/
PZ1	1	4125-PZ1-1	7,40
PZ2	1	4125-PZ2-1	7,40
PZ3	1	4125-PZ3-1	7,40

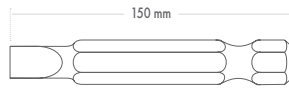

150 mm

1/4"

S2

4150

Phillips



150 mm



		Part N°	€/
PH1	1	4150-PH1-1	9,07
PH2	1	4150-PH2-1	9,07
PH3	1	4150-PH3-1	9,07

4150

Pozidriv



150 mm



		Part N°	€/
PZ1	1	4150-PZ1-1	9,07
PZ2	1	4150-PZ2-1	9,07
PZ3	1	4150-PZ3-1	9,07

4150

Torx



150 mm

		Part N°	€/
T10	1	4150-T10-1	10,42
T15	1	4150-T15-1	10,42
T20	1	4150-T20-1	10,42
T25	1	4150-T25-1	10,42
T30	1	4150-T30-1	10,42
T40	1	4150-T40-1	10,42



1/4" • 200 mm

1/4" • 250 mm

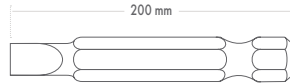

200 mm

1/4"

S2

4200

Phillips

4200

Pozidriv



200 mm



200 mm



		Part N°	€/
PH2	1	4200-PH2-1	12,52

		Part N°	€/
PZ2	1	4200-PZ2-1	12,52



250 mm

1/4"

S2

4250

Phillips

4250

Pozidriv



250 mm



250 mm



		Part N°	€/
PH2	1	4250-PH2-1	14,74

		Part N°	€/
PZ2	1	4250-PZ2-1	14,74

Screwdriver Bits

Forged Bit with a TiN coated (Titanium Nitride) increasing durability 5 times.

TiN

1/4" • 25 mm

25 mm

1/4"

S2

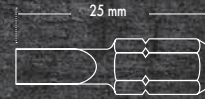

• Indicated packaging qty is the minimum to be ordered.

TiN

420

Phillips

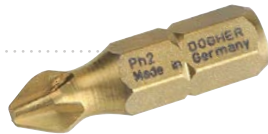

25 mm



Icon	Qty	Part N°	€/Icon	Icon	Part N°	€/Icon
	2	420-PH1-2	6,73		420-PH1-5	12,37
	2	420-PH2-2	6,73		420-PH2-5	12,37
	2	420-PH3-2	6,73		420-PH3-5	12,37

TiN

421

Pozidriv



25 mm



Icon	Qty	Part N°	€/Icon	Icon	Part N°	€/Icon
	2	421-PZ1-2	6,73		421-PZ1-5	12,37
	2	421-PZ2-2	6,73		421-PZ2-5	12,37
	2	421-PZ3-2	6,73		421-PZ3-5	12,37

TiN

422

Slot

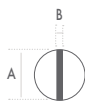

25 mm



A mm	B mm	Icon	Part N°	€/Icon
4,5	0,8		422-045-5	15,39
5,5	1		422-055-5	15,39
6,5	1,2		422-065-5	15,39

TiN

423

Torx



25 mm



Icon	Qty	Part N°	€/Icon	Icon	Part N°	€/Icon
	2	423-T10-2	7,93		423-T10-5	15,39
	2	423-T15-2	7,93		423-T15-5	15,39
	2	423-T20-2	7,93		423-T20-5	15,39
	2	423-T25-2	7,93		423-T25-5	15,39
	-	-	-		423-T27-5	15,39
	2	423-T30-2	7,93		423-T30-5	15,39
	2	423-T40-2	7,93		423-T40-5	15,39

Forged Impact Bit built for maximum durability with an special steel that provides more ductility than standard bits. The middle of the bit allows an additional flexing to buffer the bit from torque while still giving the tip the chance to rotate and further drive the fastener. Perfect Join with the Screw.

Impact Screwdriver Bits

Bluefire



- S2 high technology steel
- Max torque resistance
- High tenacity
- Specific geometry maximum durability

30 mm

1/4"

S2



1/4" • 30 mm



• Indicated packaging qty is the minimum to be ordered.

427

Phillips



30 mm



Icon	Qty	Part N°	€/Icon	Icon	Qty	Part N°	€/Icon
	2	427-PH2-2	11,87		5	427-PH2-5	25,24
	2	427-PH3-2	11,87		5	427-PH3-5	25,24

427

Pozidriv



30 mm



Icon	Qty	Part N°	€/Icon	Icon	Qty	Part N°	€/Icon
	2	427-PZ2-2	11,87		5	427-PZ2-5	25,24
	2	427-PZ3-2	11,87		5	427-PZ3-5	25,24

427

Torx



30 mm



Icon	Qty	Part N°	€/Icon	Icon	Qty	Part N°	€/Icon
	2	427-T10-2	12,08		5	427-T10-5	25,76
	2	427-T15-2	12,08		5	427-T15-5	25,76
	2	427-T20-2	12,08		5	427-T20-5	25,76
	2	427-T25-2	12,08		5	427-T25-5	25,76
	2	427-T30-2	12,08		5	427-T30-5	25,76
	2	427-T40-2	12,08				

443

Impact Magnetic Bit Holder with Ring

60 mm

1/4"

1/4"



L mm	Qty	Part N°	€/Qty
60	1	443-002	19,22

Impact Screwdriver Bits



1/4" • 50 mm

1/4" • 75 mm



50 mm 1/4" S2

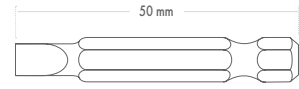

• Indicated packaging qty is the minimum to be ordered.

425

Phillips



50 mm



		Part N°	€/		Part N°	€/
PH2	2	425-PH2-2	12,89	5	425-PH2-5	27,77
PH3	2	425-PH3-2	12,89	5	425-PH3-5	27,77

425

Pozidriv



50 mm

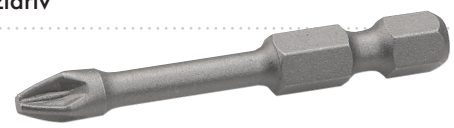

		Part N°	€/		Part N°	€/
PZ2	2	425-PZ2-2	12,89	5	425-PZ2-5	27,77
PZ3	2	425-PZ3-2	12,89	5	425-PZ3-5	27,77

426

Phillips



75 mm



		Part N°	€/
PH2	5	426-PH2-5	36,65
PH3	5	426-PH3-5	36,65

426

Pozidriv



75 mm



		Part N°	€/
PZ2	5	426-PZ2-5	36,65
PZ3	5	426-PZ3-5	36,65

1/4" • 100 mm

1/4" • 150 mm

Impact series

10X
Life



100 mm

1/4"

S2

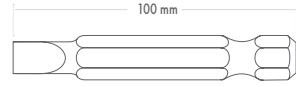

• Indicated packaging qty is the minimum to be ordered.

428

Phillips

428

Pozidriv



100 mm



100 mm



		Part N°	€/
PH2	5	428-PH2-5	39,98
PH3	5	428-PH3-5	39,98

		Part N°	€/
PZ2	5	428-PZ2-5	39,98
PZ3	5	428-PZ3-5	39,98

429

Phillips

429

Pozidriv



150 mm



150 mm



		Part N°	€/
PH2	5	429-PH2-5	47,99
PH3	5	429-PH3-5	47,99

		Part N°	€/
PZ2	5	429-PZ2-5	47,99
PZ3	5	429-PZ3-5	47,99

Screwdriver Bits



5/16" • 30 mm



30 mm 5/16" S2

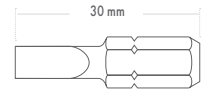

• Indicated packaging qty is the minimum to be ordered.

430 Phillips



30 mm



		Part N°	€ /
PH1	10	430-PH1-10	25,75
PH2	10	430-PH2-10	25,75
PH3	10	430-PH3-10	25,75
PH4	10	430-PH4-10	25,75

431 Pozidriv



30 mm



		Part N°	€ /
PZ1	10	431-PZ1-10	25,62
PZ2	10	431-PZ2-10	25,62
PZ3	10	431-PZ3-10	25,62
PZ4	10	431-PZ4-10	25,62

432 Slot



30 mm



A mm	B mm		Part N°	€ /
8	1,2	10	432-080-10	27,10
10	1,6	10	432-100-10	34,87
12	1,8	10	432-120-10	48,82
14	2,3	10	432-140-10	75,73

433 Torx



30 mm



		Part N°	€ /
T25	1	433-T25	4,73
T30	1	433-T30	4,73
T40	10	433-T40-10	28,94
T45	10	433-T45-10	28,94
T50	10	433-T50-10	28,94
T55	10	433-T55-10	42,38
T60	10	433-T60-10	76,86



- 30 mm
- 75 mm
- 5/16"
- S2

• Indicated packaging qty is the minimum to be ordered.

5/16" • 30 mm

5/16" • 75 mm

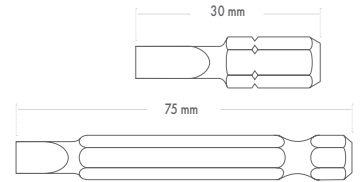

434

Torx Tamper



30 mm



		Part N°	€/
TS45	10	434-TS45-10	51,81
TS50	10	434-TS50-10	51,81
TS55	10	434-TS55-10	56,55

435

Hexagonal



30 mm



		Part N°	€/
HX4	1	435-HX4	5,78
HX5	1	435-HX5	5,78
HX6	1	435-HX6	5,78
HX8	1	435-HX8	5,78
HX10	10	435-HX10-10	33,13
HX12	10	435-HX12-10	46,38
HX14	10	435-HX14-10	47,70

436

XZN



30 mm



		Part N°	€/
XZN8	5	436-XZN8	32,73
XZN10	5	436-XZN10	32,73

436

XZN



75 mm



		Part N°	€/
XZN8	5	436-XZN8-75	37,95
XZN10	5	436-XZN10-75	37,95

Screwdriver Bits

10 mm • 30 mm

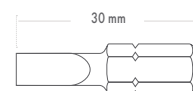

437

Hexagonal



30 mm



		Part N°	€/
HX4	5	437-HX4	14,41
HX5	5	437-HX5	14,41
HX6	5	437-HX6	14,41
HX7	5	437-HX7	14,41
HX8	5	437-HX8	14,41
HX10	5	437-HX10	14,41
HX12	5	437-HX12	15,39

437

Ribe



30 mm



		Part N°	€/
RIBE6	5	437-RIBE6	16,83
RIBE7	5	437-RIBE7	16,83
RIBE8	5	437-RIBE8	16,83
RIBE9	5	437-RIBE9	16,83
RIBE10	5	437-RIBE10	16,83
RIBE12	5	437-RIBE12	22,47
RIBE14	5	437-RIBE14	25,69

437

XZN



30 mm



		Part N°	€/
XZN5	5	437-XZN5	15,15
XZN6	5	437-XZN6	15,15
XZN8	5	437-XZN8	15,15
XZN10	5	437-XZN10	15,15
XZN12	5	437-XZN12	19,56
XZN14	5	437-XZN14	23,13

437

Torx



30 mm



		Part N°	€/
T20	5	437-T20	15,15
T25	5	437-T25	15,15
T30	5	437-T30	15,15
T40	5	437-T40	15,15
T45	5	437-T45	15,15
T50	5	437-T50	15,15
T55	5	437-T55	15,15

437

Robertson



30 mm



		Part N°	€/
R8	5	437-R8	16,05
R10	5	437-R10	17,24

10 mm • 75 mm

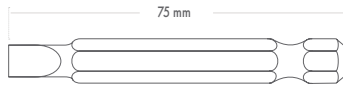

437

Hexagonal



75 mm



		Part N°	€/
HX4	5	437-HX4-75	22,14
HX5	5	437-HX5-75	22,15
HX6	5	437-HX6-75	22,15
HX7	5	437-HX7-75	22,15
HX8	5	437-HX8-75	22,15
HX10	5	437-HX10-75	22,15
HX12	5	437-HX12-75	23,12

10 mm • 115 mm

HX10	1	437-HX10-115	23,69
-------------	---	---------------------	--------------

437

Ribe



75 mm



		Part N°	€/
RIBE6	5	437-RIBE6-75	24,44
RIBE7	5	437-RIBE7-75	24,44
RIBE8	5	437-RIBE8-75	24,44
RIBE9	5	437-RIBE9-75	27,21
RIBE10	5	437-RIBE10-75	27,21
RIBE12	5	437-RIBE12-75	33,17
RIBE14	5	437-RIBE14-75	43,01

437

XZN



75 mm



		Part N°	€/
XZN5	5	437-XZN5-75	18,05
XZN6	5	437-XZN6-75	18,05
XZN8	5	437-XZN8-75	18,05
XZN10	5	437-XZN10-75	23,03
XZN12	5	437-XZN12-75	28,49

437

Torx



75 mm



		Part N°	€/
T20	5	437-T20-75	20,68
T25	5	437-T25-75	20,68
T30	5	437-T30-75	20,68
T40	5	437-T40-75	20,73
T45	5	437-T45-75	20,73
T50	5	437-T50-75	20,73
T55	5	437-T55-75	29,04

10 mm • 115 mm

T55	1	437-T55-115	31,37
------------	---	--------------------	--------------

Screwdriver Bits

Screwdriver Bits Sets



10 mm

438

Hexagonal Screwdriver Bit Set and Bit Coupler

15 Pcs

10 mm

S2



Bit Coupler

10 mm ▶  ◀ 1/2" (543-027)

 10 mm x 30 mm HX4 • HX5 • HX6 • HX7 • HX8 • HX10 • HX12

 10 mm x 75 mm HX4 • HX5 • HX6 • HX7 • HX8 • HX10 • HX12

Part N°	€
438-004	54,24

438

Ribe Screwdriver Bit Set and Bit Coupler

15 Pcs

10 mm

S2



Bit Coupler

10 mm ▶  ◀ 1/2" (543-027)

 10 mm x 30 mm RIBE6 • RIBE7 • RIBE8 • RIBE9
RIBE10 • RIBE12 • RIBE14

 10 mm x 75 mm RIBE6 • RIBE7 • RIBE8 • RIBE9
RIBE10 • RIBE12 • RIBE14

Part N°	€
438-005	74,02

438

XZN Screwdriver Bit Set and Bit Coupler

11 Pcs

10 mm

S2



Bit Coupler

10 mm ▶  ◀ 1/2" (543-027)

 10 mm x 30 mm XZN5 • XZN6 • XZN8 • XZN10 • XZN12

 10 mm x 75 mm XZN5 • XZN6 • XZN8 • XZN10 • XZN12

Part N°	€
438-006	48,92

438

Torx Screwdriver Bit Set and Bit Coupler

15 Pcs

10 mm

S2



Bit Coupler

10 mm ▶  ◀ 1/2" (543-027)

 10 mm x 30 mm T20 • T25 • T30 • T40 • T45 • T50 • T55

 10 mm x 75 mm T20 • T25 • T30 • T40 • T45 • T50 • T55

Part N°	€
438-007	52,97

440 Magnetic Nut Driver



Hex Size	Qty	Part N°	€/Pack
5	2	440-050	11,97
5,5	2	440-055	11,97
6	2	440-060	11,97
1/4	2	440-1/4	11,97
7	2	440-070	11,97
5/16	2	440-5/16	12,76
8	2	440-080	12,21
3/8	2	440-3/8	12,76
10	2	440-100	12,84
11	2	440-110	13,09
12	2	440-120	13,40
13	2	440-130	13,68

441 Long Magnetic Nut Driver



Hex Size	Qty	Part N°	€/Pack
6	2	441-060	13,17
7	2	441-070	13,17
8	2	441-080	13,44
10	2	441-100	14,12
11	2	441-110	14,39
12	2	441-120	14,74
13	2	441-130	15,36

440 Magnetic Nut Drivers Kits

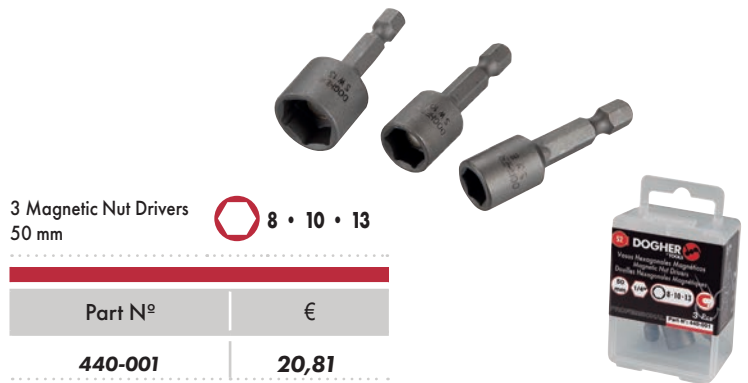

3 Magnetic Nut Drivers 50 mm 8 • 10 • 13

Part N°	€
440-001	20,81



7 Magnetic Nut Drivers 50 mm 6 • 7 • 8 • 10
13 • 5/16 • 3/8

Part N°	€
440-005	50,76



3 Magnetic Nut Drivers 50 mm 8 • 5/16 • 3/8
4 Magnetic Nut Drivers 65 mm 6 • 7 • 10 • 13

Part N°	€
440-006	51,96



3 Magnetic Nut Drivers 65 mm 8 • 10 • 13

Part N°	€
441-001	22,90



7 Magnetic Nut Drivers 65 mm 6 • 7 • 8 • 10
11 • 12 • 13

Part N°	€
441-005	55,86

Screwdriver Bits



443

Magnetic Bit Holder with Ring

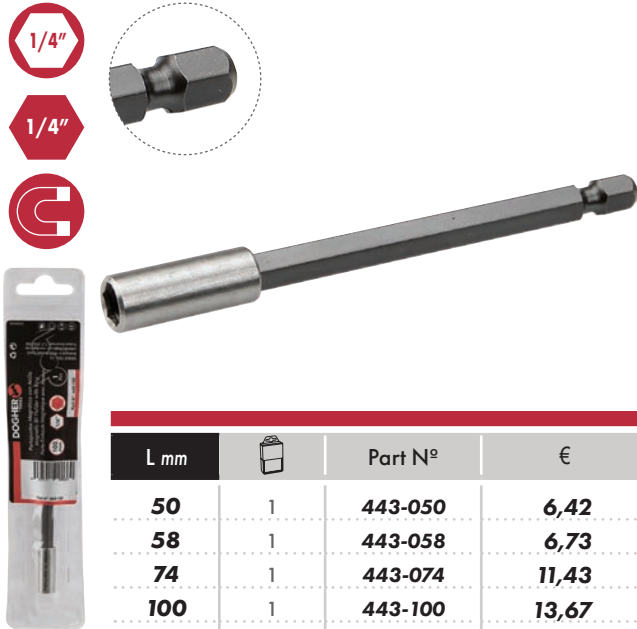

L mm		Part N°	€
50	1	443-050	6,42
58	1	443-058	6,73
74	1	443-074	11,43
100	1	443-100	13,67
200	1	443-200	17,11

445

SDS Plus Magnetic Bit Holder with Ring



L mm		Part N°	€
78	1	445-001	15,76

440

Magnetic Nut Drivers & Holders Kits



3 Magnetic Nut Drivers 50 mm
2 Holders 50-74 mm

6 • 7 • 8
10 • 13

Part N°	€
440-007	56,74

5 Magnetic Nut Drivers
2 Holders 50-58 mm

8 • 10 • 13
8 • 10

50 mm
65 mm

Part N°	€
440-008	53,85

444

Flexible extension

1/4"
1/4"
300 mm



Part N°	€
444-001	32,53

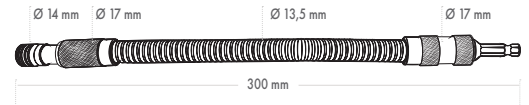

443

Offset bit holder for 1/4" bits

1/4"
1/4"



- Suitable for screwdriver bits and hex shank drill bits
- Designed for a comfortable work in limited spaces
- To be used exclusively in cordless drivers

Part N°	€
443-001	32,31

Screwdriver Bit Sets

438

Screwdriver Bit Set and Bit Holder

32 Pcs
1/4"
25 mm



- ✦ T06 • T07 • T08 • T09 • T10 • T15 • T20 • T25 • T27 • T30 • T40
 ⬢ HX3 • HX4 • HX5 • HX6
⊖ 3 • 4 • 5 • 6 • 7
 ✦ PZ0 • PZ1 • PZ2 • PZ3
 ✦ PH0 • PH1 • PH2 (x3) • PH3

Adapter

1/4" ◀ ▶ 1/4" (509-030)

Magnetic Bit Holder with Ring • 60 mm

1/4" ◀ ▶ 1/4"

Part N°	€
438-001	41,94

338

Screwdriver Bit Set and Ratchet Handle

32 Pcs
1/4"
25 mm



- ✦ T06 • T07 • T08 • T09 • T10 • T15 • T20 • T25 • T30 • T40
 ⬢ HX3 • HX4 • HX5 • HX6
⊖ 3 • 4 • 5 • 6 • 7
 ✦ PZ0 • PZ1 • PZ2 • PZ3
 ✦ PH0 • PH1 • PH2 • PH3

✦ RO • R1 • R2 • R3

Ratchet Handle



Part N°	€
438-002	44,60

Screwdriver Bits

Screwdriver Bit Sets



438

Screwdriver Bit Set and Ratchet Handle

11

Pcs

1/4"

25

mm



PH1 • PH2 • PH3

PZ1 • PZ2 • PZ3

3 • 4 • 5 • 6

Ratchet Handle



Part N°

€

438-003

39,69



10

Pcs

230 x 210 x 155 mm

Part N°

€

438-003J

396,90

438

Screwdriver Bits Set with Flexible Ratcheting Screwdriver

58

Pcs

1/4"

25

mm



3 • 4 • 4,5 • 5 • 6 • 7 • 8

PZ0 • PZ1 • PZ2 • PZ3

1 • 2 • 3

PH0 • PH1 • PH2 • PH3

TW1 • TW2 • TW3 • TW4

HX1,5

HXS2,0 • HXS2,5 • HXS3,0 • HXS4,0 • HXS5,0 • HXS6,0

R0 • R1 • R2 • R3

TQ06 • TQ08 • TQ10

T5 • T6

TS7 • TS8 • TS9 • TS10 • TS15 • TS20 • TS25 • TS30 • TS40

XZN4 • XZN5 • XZN6 • XZN8

4 • 6 • 8 • 10

Magnetic Bit Holder with Ring • 60 mm / Screwdriver Ref. 343-007

Adapter 1/4" ◀ ▶ 1/4" (509-030)

Part N°

€

438-008

71,19

7

Pcs



275 x 290 x 140 mm

Part N°

€

438-008J

498,33